

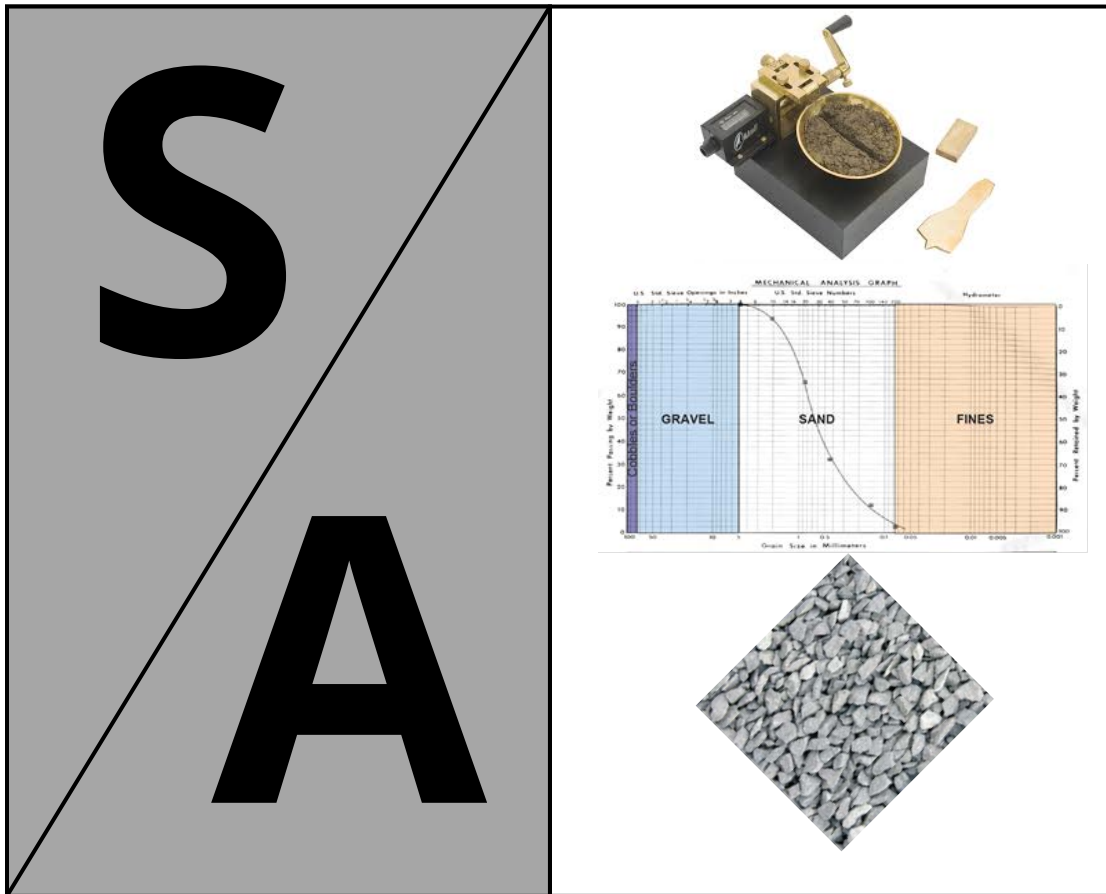

**TDOT**

Department of  
Transportation



**Soils and Aggregate Technician Course  
Tennessee Department of Transportation**

**Volume 18.2**

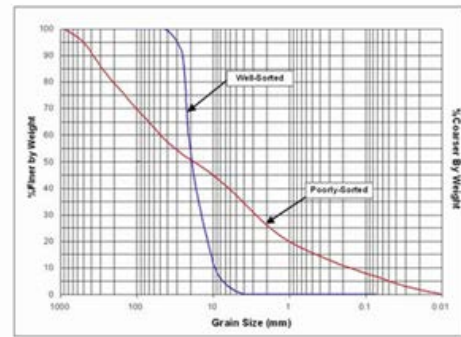

## Soils and Aggregate Technician Course

---

**Instructors:**

Jason Mellons, P.E.	<a href="mailto:michael.j.mellons@tn.gov">michael.j.mellons@tn.gov</a> (615) 350-4152
Derek Gaw, P.E.	<a href="mailto:derek.gaw@tn.gov">derek.gaw@tn.gov</a> (615) 350-4106
Traci Smith	<a href="mailto:traci.smith@tn.gov">traci.smith@tn.gov</a> (615) 350-4126
David Black	<a href="mailto:david.black@tn.gov">david.black@tn.gov</a> (615) 350-4163
Chris Hampton	<a href="mailto:c.w.hampton@tn.gov">c.w.hampton@tn.gov</a> (615) 350-3314

**Training Coordinator:** Kim Whitby [kimberly.whitby@tn.gov](mailto:kimberly.whitby@tn.gov)  
(615) 350-4158

Tennessee Department of Transportation  
Division of Materials and Tests • Field Operations  
6601 Centennial Blvd. • Nashville • Tennessee • 37243-0360  
Phone 615.350.4100 • Fax 615.350.4128

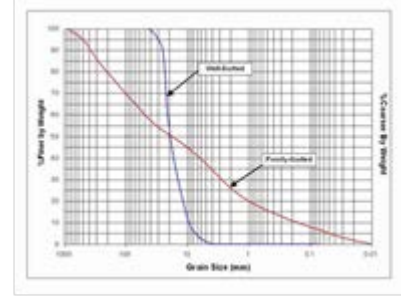

# Soils & Aggregate Technician Course

Volume 18.2

## Class Schedule

### Day 1:

1. Registration
2. Introduction to the Course
3. Sampling Aggregates
4. Reducing Samples of Aggregates to Testing Size
5. Total Evaporable Moisture Content of Aggregate by Drying
- 6. Break**
7. Material Finer Than the No. 200 (75 $\mu$ m)
8. Sieve Analysis of Fine and Coarse Aggregate
- 9. Lunch (Provided)**
10. Embankments and Embankment Materials
11. Compaction and Density Concepts
- 12. Break**
13. Embankment Placement
14. Quality Acceptance Testing

### Day 2:

15. Review for Exam
16. Written Exam

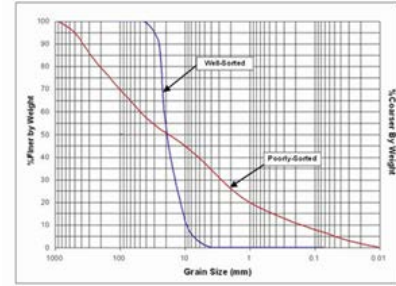

# Soils & Aggregate Technician Course

Tennessee Department of Transportation

Volume 18.2

## Table of Contents

I. Introduction.....	1
1. Sampling Aggregates .....	7
2. Reducing Samples of Aggregates to Testing Size.....	20
3. Total Evaporable Moisture Content of Aggregate by Drying.....	28
4. Material Finer Than the No. 200 (75µm).....	36
5. Sieve Analysis of Fine and Coarse Aggregate.....	46
6. Embankments and Embankment Materials.....	61
7. Compaction and Density Concepts .....	78
8. Embankment Placement .....	89
9. Quality Acceptance Testing.....	106
10. TDOT Forms.....	128
11. SOP 1-1 .....	130
12. SOP 7-1 .....	140
13. SOP 7-2.....	145
14. TDOT Specs.....	150

# Welcome!

Soils and Aggregate Technician Certification



## Introduction

- Technician Certification Program
- Purpose
- Who's Who
- Course Highlights
- Written Examination
- Results/Certification
- Resources/Contacts
- Summary/Questions



S & A Technician Certification

## Instructors

- Jason Mellons, P.E.  
[michael.j.mellons@tn.gov](mailto:michael.j.mellons@tn.gov)
- Derek Gaw, P.E.  
[derek.gaw@tn.gov](mailto:derek.gaw@tn.gov)
- Traci Smith  
[traci.smith@tn.gov](mailto:traci.smith@tn.gov)
- David Black  
[david.black@tn.gov](mailto:david.black@tn.gov)
- Chris Hampton  
[c.w.hampton@tn.gov](mailto:c.w.hampton@tn.gov)

S & A Technician Certification



## Technician Certification Program

- Asphalt Roadway Inspector
- Asphalt Plant Inspector
- Asphalt Mix Design
- Concrete Field Testing
- Concrete Plant Quality Control
- Concrete Mix Design
- **Soils and Aggregate**
- Nuclear Gauge Safety (TDOT Employees Only)

S & A Technician Certification



## Purpose of Certification

- To ensure proper performance of tests
- To improve reliability of results
- For quality control
- To comply with federal requirements

S & A Technician Certification



## Course Highlights

- Course schedule
  - Slide presentations
    - Introduction to Soils and Aggregates
    - 5 Test methods for Aggregate
    - Soil Testing and Properties
    - TDOT Specifications
  - Written exam
  - Results
  - Certification
- Recertification
  - Every 5 years

S & A Technician Certification



## Written Examination

- Consists of:
  - 51 questions
  - Open-book
  - Two hours to complete
- To Pass:
  - Must get 70% overall

S & A Technician Certification



## Results

- Available within one week of completion
- Contact the Headquarters Materials & Tests Training Coordinator, Kim Whitby
  - [kimberly.whitby@tn.gov](mailto:kimberly.whitby@tn.gov)
  - 615-350-4158

S & A Technician Certification





## Resources

- Course materials
  - Course textbook
  - Presentation slides and videos
- TDOT
  - Standard Specifications, January 1, 2015
  - Special Provisions
- Contacts
  - Region 1: Brad Baskette
  - Region 2: Tony Renfro
  - Region 3: Kevin Isenberg
  - Region 4: Mitch Blankenship

S &amp; A Technician Certification





## Resources

- Tennessee Department of Transportation
  - <https://www.tn.gov/tdot.html>
- American Road & Transportation Builders Association
  - <https://www.artba.org/>
- Tennessee Road Builders Association
  - [www.trba.org/](http://www.trba.org/)
- Tennessee Ready Mixed Concrete Association
  - [www.tnconcrete.org/](http://www.tnconcrete.org/)
- American Association of State Highway Transportation Officials
  - <https://www.transportation.org>
- American Society for Testing and Materials
  - <https://www.astm.org/>
- American Concrete Institute
  - <https://www.concrete.org/>
- Construction Materials Engineering Council
  - <https://www.cmec.org/>
- Portland Cement Association
  - [www.cement.org/](http://www.cement.org/)

S &amp; A Technician Certification



## ADA Notice of Requirements

- Can be found at the following website:
  - <https://www.tn.gov/tdot/government/g/public-accessibility-office/ada.html>
- To be in compliance with TDOTs requirements listed on the website above, it is our goal to provide reasonable accommodations to those who identify themselves as having a disability and request such accommodations.
- Please feel free to bring it to any of the course instructors and accommodations will be administered as discretely as possible.

 Concrete Mix Design Technician Certification



## Questions



# 1

## **Sampling of Aggregates**

**AASHTO T 2**

**ASTM D 75**

## ***TDOT Standard Method of Test for Sampling of Aggregates***

### References



TDOT Standard Specifications  
AASHTO T 2  
ASTM D 75



## **Apparatus**

- **Shovel**
- **Scoops**
- **Brushes**
- **Sampling tubes**
- **Sample containers**
- **Tags**



and Aggregate Technician Certification

## Purpose

- **Preliminary investigation of the potential source of supply**
  - Sample at source
  - Complete quality testing (dependent upon application)
- **Control of the product at the source**
- **Control of the operations at the site of use**
  - Project site
  - Concrete plant
- **Acceptance or rejection of the materials**
  - TDOT Standard Specifications



## Size of Aggregate

- **Nominal maximum size of aggregate is the smallest sieve opening through which the entire amount of the aggregate is permitted to pass.**
- **Maximum size of aggregate is the smallest sieve opening through which the entire amount of aggregate is required to pass.**



# Sizes of Coarse Aggregate Table 903.22-1

Size	Nominal Size	4"	3.5"	3"	2.5"	2"	1.5"	1"	¾"	½"	⅜"	#4	#8	#16	#50	#100
1	3.5-1.5"	100	90-100	-	25-60	-	0-15	-	0-5							
2	2.5-1.5"			100	90-100	35-70	0-15		0-5							
24	2.5-¾"			100	90-100		25-60		0-10	0-5						
3	2-1"				100	90-100	35-70	0-15		0-5						
357	2"-#4				100	95-100		35-70		10-30		0-5				
4	1.5-¾"					100	90-100	20-55	0-15		0-5					
467	1.5"-#4					100	95-100		35-70		10-30	0-5				
5	1-½"						100	90-100	20-55	0-10	0-5					
56	1-⅜"						100	90-100	40-85	10-40	0-15	0-5				
57	1"-#4						100	95-100		25-60		0-10	0-5			
6	¾ - ⅜"							100	90-100	20-55	0-15	0-5				
67	¾" - #4							100	90-100		20-55	0-10	0-5			
68	¾" - #8							100	90-100		30-65	5-25	0-10	0-5		
7	½" - #4								100	90-100	40-70	0-15	0-5			
78	½" - #8								100	90-100	40-75	5-25	0-10	0-5		
8	⅜" - #8									100	85-100	10-30	0-10	0-5		
89	⅜" - #16									100	90-100	20-55	5-30	0-10	0-5	
9	#4 - #16										100	85-100	10-40	0-10	0-5	
10	#4-screenings										100	85-100				10-30

# Field Sample Size



D75/D75M – 13

TABLE 1 Minimum Size of Field Samples

Aggregate Size <sup>A</sup> (Nominal Maximum Size)	Field Sample Mass, min, kg <sup>B</sup> [lb]	Field Sample Volume, min, L [gal]
Fine Aggregate		
2.36 mm [No. 8]	10 [22]	8 [2]
4.75 mm [No. 4]	10 [22]	8 [2]
Coarse Aggregate		
9.5 mm [3/8 in.]	10 [22]	8 [2]
12.5 mm [1/2 in.]	15 [35]	12 [3]
19.0 mm [3/4 in.]	25 [55]	20 [5]
25.0 mm [1 in.]	50 [110]	40 [10]
37.5 mm [1 1/2 in.]	75 [165]	60 [15]
50 mm [2 in.]	100 [220]	80 [21]
63 mm [2 1/2 in.]	125 [275]	100 [26]
75 mm [3 in.]	150 [330]	120 [32]
90 mm [3 1/2 in.]	175 [385]	140 [37]

# Aggregate Production and Use

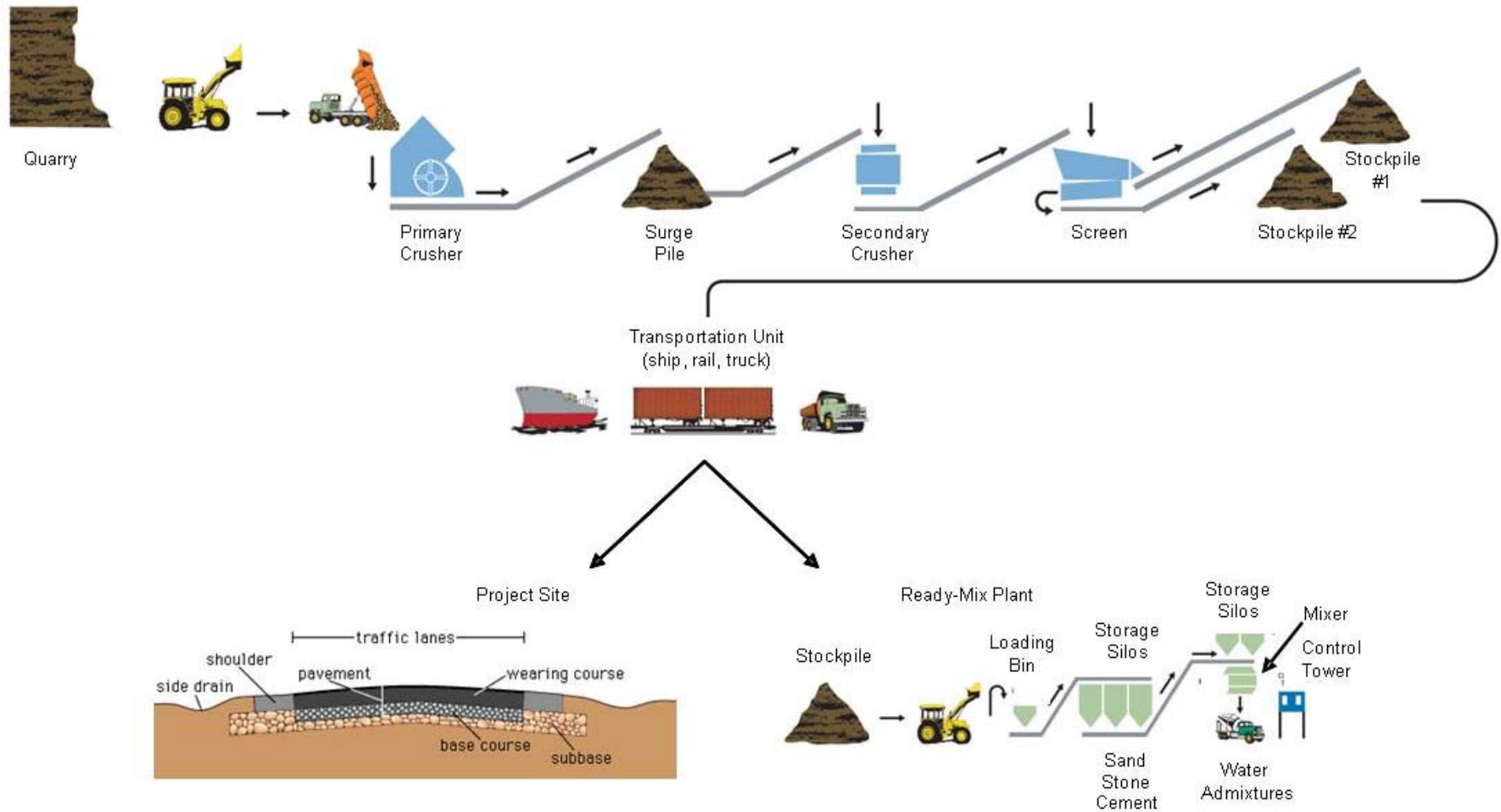

<https://www.youtube.com/watch?v=qWEci7TbjBk&feature=youtu.be>



# Aggregate Production and Use

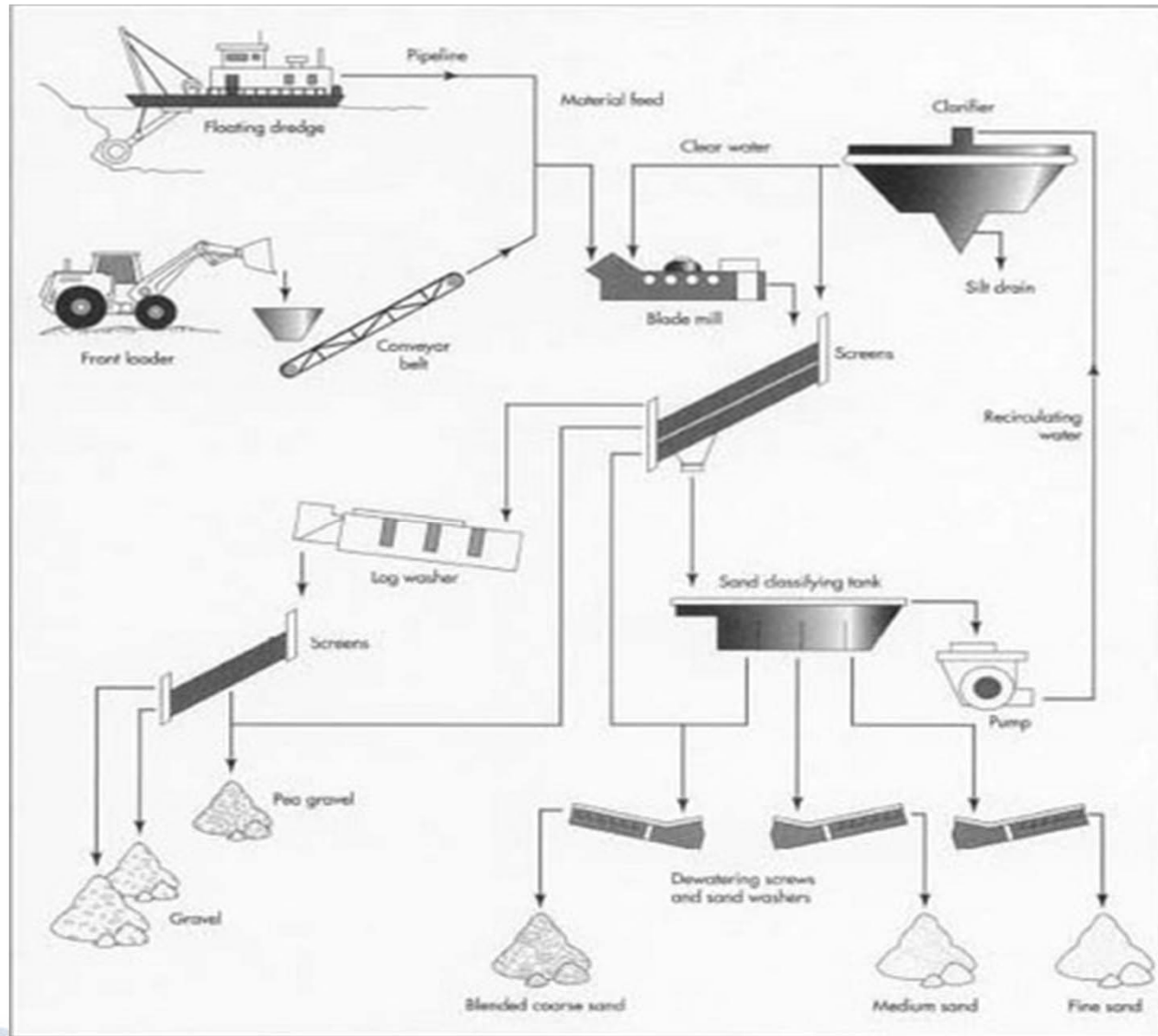

## Methods of Sampling

- **Flowing aggregate stream**
- **Conveyor belt**
- **Stockpiles**
  - **With power equipment**
  - **Without power equipment**
- **Roadways**
- **Transportation units**

## Flowing Aggregate Stream

- **From bins, for example**
- **Three increments**
- **Each increment obtained using a suitable sampling device**
- **Device must be capable of interrupting the entire flow of material as it passes off the belt**

## Conveyor Belts

- **Three increments**
- **Production suspended while sampling**
- **Designated sampling area**
- **Templates useful for defining sampling area**
- **All material within sampling area is removed including fines (with a brush)**



## Stockpiles

- **Stockpile must be checked for segregation and noted in log**
- **Segregation is the separation of varying sizes of aggregate**
- **Power equipment is recommended**
- **Portions collected at various locations around the main stockpile**

## With Power Equipment

- Loader enters stockpile with bucket approximately 6" above ground level
- Loader bucket is raised perpendicular to the ground
- Bucket is tilted forward to roll material out into a separate stockpile



and Aggregate Technician Certification

## With Power Equipment

- The loader is then used to backblade the smaller stockpile **ONE** time
- Divide the sample pad into 4 quadrants, and sample equal amounts
- Avoid sampling within 1 ft. of sample pad edge
- The **FOUR** increments are then combined to comprise the final field sample

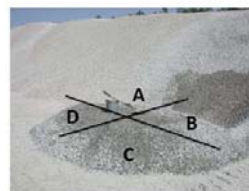

and Aggregate Technician Certification

## Without Power Equipment

If power equipment is not available:

- The pile is visually divided into three even sections: top third, mid-point, and bottom third of the elevation of the stockpile
- Portions are obtained from each section at least 12" below the surface by removing the outer layer of material
- The three increments are then combined to comprise the final field sample

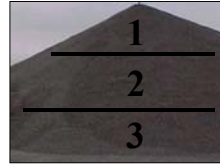

and Aggregate Technician Certification

## Without Power Equipment

In lieu of shoveling:

- Sampling tubes may be used on fine aggregate only
- Sample shall be taken at a minimum height of 3 ft from the surrounding grade
- At least five tube insertions randomly spaced across face of stockpile



and Aggregate Technician Certification

## Without Power Equipment (Sampling Tube)

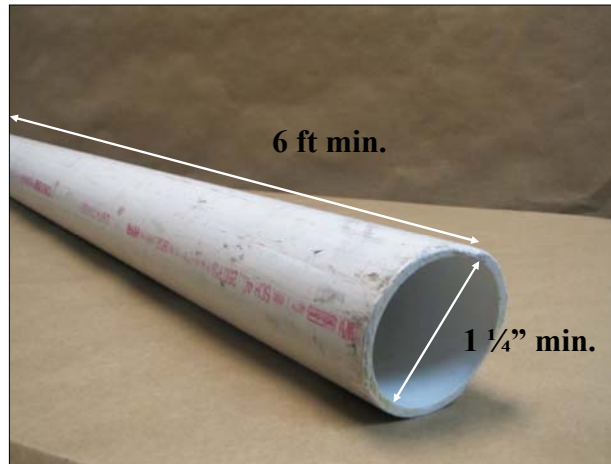

## Roadways

- **Three increments**
- **Sample obtained from uncompacted or loosely-compacted base or sub base material**
- **Predetermined random locations**
- **Full depth of layer must be sampled**
- **Avoid contamination from underlying material**



## Transportation Units

- **Railroad cars, barges, trucks**
- **Avoid if at all possible**
- **Power equipment is recommended**
- **Various levels and random locations**
- **Three or more trenches**
  - **Three increments from each trench**

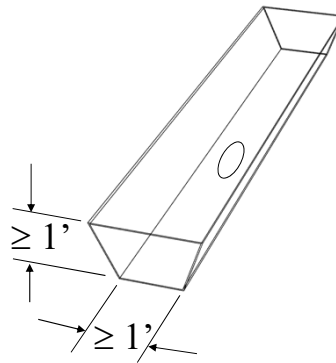

and Aggregate Technician Certification

## Sample Containers

- **Durable**
- **Able to be carried**  
[ ≤ 50 lbs. (23 kg) ]
- **Portion the sample if necessary**
- **Appropriate container for test to be performed**



and Aggregate Technician Certification

# Tagging the Sample

Project Number: 55001-3231-18  
Date Sampled: 11 Mar 02 Submitted: 12 Mar 02  
Sampled by: F. Flintstone  
Submitted by: F. Flintstone  
Producer: Stone Materials, Inc.  
Pit Number: 185 Sampled from: Stockpile  
County: Davidson Region: 3



and Aggregate Technician Certification



# Questions





# 2

**Reducing Samples of Aggregate to Testing**

**Size AASHTO R 76**

**ASTM C 702**

## *TDOT Standard Method of Test for* **Reducing Samples of Aggregate to Testing Size**

### References



TDOT Standard Specifications  
AASHTO R 76  
ASTM C 702



## **Methods of Reduction**

- **Method A - Mechanical Splitter**
- **Method B - Cone and Quarter**
- **Method C - Miniature Stockpile**



## To Determine Method

- **Moisture condition of the aggregate**

- **Dry**

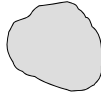

- **Moist**



- **SSD/Absorption**



- **Wet/Free Moisture**



and Aggregate Technician Certification

## To Determine Method

- **Size of aggregate**

- **Coarse**



- **Fine**









- **Combined**



and Aggregate Technician Certification

## Determine Method

Moisture \ Aggregate Size	Coarse	Combined	Fine
Drier than saturated-surface-dry and SSD	 A, B	 A, B	 A
Free moisture on surface	 A, B	 B	 B, C

} Splitting Method

- Method A - Mechanical Splitter
- Method B - Cone and Quarter
- Method C - Miniature Stockpile



and Aggregate Technician Certification

## Mechanical Splitter / Method A

### For Coarse and Combined Aggregate

- Even number of chutes
- Chutes of equal width
- At least 8 chutes
- Individual chutes about 50% larger than largest particles



and Aggregate Technician Certification

## Mechanical Splitter / Method A

### For Fine Aggregate

- Even number of chutes
- Chutes of equal width
- At least 12 chutes
- Individual chutes  $\frac{1}{2}$ " to  $\frac{3}{4}$ " wide



and Aggregate Technician Certification

## Cone and Quarter / Method B

- Cone the sample on a hard, clean, level surface.
- Turn sample over 3 times and place into a cone.
- Flatten the cone to a uniform thickness.
- Diameter = 4 to 8 times the thickness



and Aggregate Technician Certification

## Cone and Quarter / Method B

- Divide the flattened cone.
- After dividing, remove two diagonal quarters (including fines).
- Mix and quarter the remaining material until sample is adequately reduced.



and Aggregate Technician Certification

## Cone and Quarter / Method B

### Fine Aggregate



and Aggregate Technician Certification

## Quartering Alternative/Method B



Mix by rolling on canvas.



Flatten aggregate pile to a diameter 4 to 8 times the thickness.



and Aggregate Technician Certification

## Quartering Alternative/Method B



Divide the aggregate into four separate quarters using a shovel or stick.



Remove two diagonally opposite quarters including fines.



and Aggregate Technician Certification

## Miniature Stockpile / Method C

- Place sample on hard, clean, level surface
- Mix thoroughly by turning over three times
- Form a cone with the last turning
- Flatten, if desired, to a uniform thickness
- Select at least five increments at random locations using a shovel, scoop, or spoon



and Aggregate Technician Certification

## Miniature Stockpile / Method C



and Aggregate Technician Certification





# 3

**Total Evaporable Moisture Content of  
Aggregate by Drying  
AASHTO T 255  
ASTM C 566**

*TDOT Standard Method of Test for*  
**Total Evaporable Moisture Content of  
Aggregate by Drying**

References



TDOT Standard Specifications  
AASHTO T 255  
ASTM C566



## Apparatus

- **Balance**
- **Heat Source**
- **Sample Container**
- **Stirring Spoon**



# Sample Size

**TABLE 1 Sample Size for Aggregate**

Nominal Maximum Size of Aggregate, mm (in.) <sup>A</sup>	Mass of Normal Weight Aggregate Sample, min, kg <sup>B</sup>
4.75 (0.187) (No. 4)	0.5
9.5 (3/8)	1.5
12.5 (1/2)	2
19.0 (3/4)	3
25.0 (1)	4
37.5 (1 1/2)	6
50 (2)	8
63 (2 1/2)	10
75 (3)	13
90 (3 1/2)	16
100 (4)	25
150 (6)	50

<sup>A</sup> Based on sieves meeting Specification E11.

<sup>B</sup> Determine the minimum sample mass for lightweight aggregate by multiplying the value listed by the dry-loose unit mass of the aggregate in kg/m<sup>3</sup> (determined using Test Method C29/C29M) and dividing by 1600.



and Aggregate Technician Certification

# Samples



and Aggregate Technician Certification

## Determine Sample Mass

- Weigh the sample to the nearest 0.1 of a unit of the original sample mass



6285.6 g



and Aggregate Technician Certification

## Dry the Sample

- Dry the aggregate to a constant mass in an oven at  $110 \pm 5^\circ\text{C}$  ( $230 \pm 9^\circ\text{F}$ )
- Allow the material to cool



and Aggregate Technician Certification

## Reweigh the Sample

- Weigh the sample to the nearest 0.1 of a unit of the original sample mass



6163.8 g

## Calculations

$$P_{Moisture, Total} = \frac{M_{Original} - M_{Dry}}{M_{Dry}} \times 100$$

$$P = \frac{W - D}{D} \times 100$$

## Problem

### Given:

- Weight of the original sample ( $W$ ) = 1092.4 g
- Weight of sample after drying ( $D$ ) = 1080.5 g

### Determine:

Total percent ( $P$ ) moisture content of the aggregate.

## Solution

$$P = \frac{W - D}{D} \times 100$$

## Practice

Sample Number	Original Weight	Dry Weight	Moisture Content
1	588.3	570.9	
2	1556.8	1540.9	
3	1225	1220.1	
4	1665.2	1650.5	

## Solutions

1	588.3	570.9	
2	1556.8	1540.9	
3	1225.0	1220.1	
4	1665.2	1650.5	

$$p_1 =$$

$$p_2 =$$

$$p_3 =$$

$$p_4 =$$



<b>DRY</b> 900g	<b>MOIST</b> 930g	<b>SSD</b> 955g	<b>WET</b> 975g
--------------------	----------------------	--------------------	--------------------

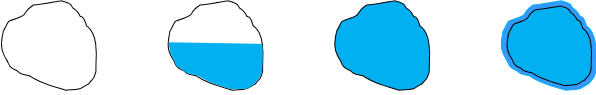

**Determine the percent moisture content in the wet condition:**

**Determine the percent moisture of the aggregate at SSD (Absorption):**

TN TDOT  
Department of  
Transportation

and Aggregate Technician Certification

<b>DRY</b> 900g	<b>MOIST</b> 930g	<b>SSD</b> 955g	<b>WET</b> 975g
--------------------	----------------------	--------------------	--------------------

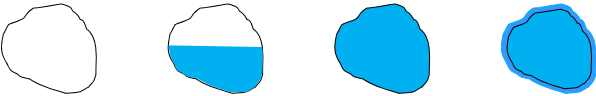

**Determine the percent of free moisture on the sample:**

**Determine the amount of water the aggregate has in the wet condition:**

TN TDOT  
Department of  
Transportation

and Aggregate Technician Certification



# 4

**Materials Finer Than 75- $\mu\text{m}$  (No.200) Sieve**

**In Mineral Aggregates by Washing**

**AASHTO T 11**

**ASTM C 117**

*TDOT Standard Method of Test for*  
**Materials Finer Than 75- $\mu$ m (No. 200) Sieve in Mineral  
Aggregates by Washing**

References



TDOT Standard Specifications  
AASHTO T 11  
ASTM C 117



## Apparatus

- **Balance**
- **Sieves (#16 & #200)**
- **Container**
- **Oven**
- **Wetting Agent**



## Sample Size

Nominal Maximum Size <sup>A</sup>	Minimum Mass, g
4.75 mm (No. 4) or smaller	300
9.5 mm (3/8")	1000
12.5 mm to 19.0 mm (1/2" to 3/4")	2500
25 mm (1") or larger	5000

<sup>A</sup> Based on sieve sizes meeting Specification E11.

## Minus 200 Material



## Dry the Material

- Dry the aggregate to a constant mass in an oven at  $110 \pm 5^{\circ}\text{C}$  ( $230 \pm 9^{\circ}\text{F}$ )
- Allow the material to cool



and Aggregate Technician Certification

## Determine the Sample Mass

- Weigh the sample to the nearest 0.1 of a unit of the original sample mass



and Aggregate Technician Certification

## Two Procedures

### Procedure A - Washing with plain water

- Dust of Fracture



### Procedure B - Washing using a wetting agent

- Clay Particles



and Aggregate Technician Certification

## Procedure

- Place the sample in the container
- Add water to cover the sample
- Add wetting agent if performing Procedure B



and Aggregate Technician Certification

## Procedure

- **Agitate the sample**
- **Use a spoon to stir, if desired**
- **Ensure complete separation of particles**



and Aggregate Technician Certification

## Procedure

- **Pour the wash water with suspended solids over the nested sieves**



and Aggregate Technician Certification



## Procedure

- Repeat the washing with plain water
- Repeat until wash water is clear
- Use wetting agent first wash only



and Aggregate Technician Certification

## Dry the Material

- Dry the aggregate to a constant mass in an oven at  $110 \pm 5^{\circ}\text{C}$  ( $230 \pm 9^{\circ}\text{F}$ )
- Allow the material to cool



and Aggregate Technician Certification

## Determine the Sample Mass

- Weigh the sample to the nearest 0.1 of a unit of the original sample mass



## Calculations

$$P_{\leq 75 \mu m} = \frac{M_{Dry, Before} - M_{Dry, After}}{M_{Dry, Before}} \times 100$$

## Results

- If the amount of material finer than 75- $\mu\text{m}$  is less than 10% then report the results to the nearest 0.1.
- If the amount of material finer than 75-  $\mu\text{m}$  is greater than 10% then report the results to the nearest whole number.

## Problem

### Given:

- Original mass of the sample = 595.6 g
- Mass of the sample after washing = 579.3 g

### Determine:

- The percent (P) of material finer than the No. 200 sieve in the sample.

## Solution

$$P_{\leq 75 \mu m} = \frac{M_{\text{Dry, Before}} - M_{\text{Dry, After}}}{M_{\text{Dry, Before}}} \times 100$$

$$P_{\leq 75 \mu m} =$$

## Practice

### Given:

- Original mass of the sample = 6895.5 g
- Mass of the sample after washing = 6045.0 g

### Determine:

- The percent (P) of material finer than the No. 200 sieve in the sample

## Solution

$$P_{\leq 75 \mu m} = \frac{M_{Dry, Before} - M_{Dry, After}}{M_{Dry, Before}} \times 100$$

$$P_{\leq 75 \mu m} =$$



# 5

## **Sieve Analysis of Fine and Coarse Aggregates**

**AASHTO T 27**

**ASTM C 136**

## *TDOT Standard Method of Test for* **Sieve Analysis of Fine and Coarse Aggregates**

### References



TDOT Standard Specifications  
AASHTO T 27  
ASTM C 136



## **Apparatus**

- **Balance**
- **Oven**
- **Sieves**
- **Mechanical Shaker**



Aggregate and Aggregate Technician Certification

# Aggregate Gradation

**Well-Graded**

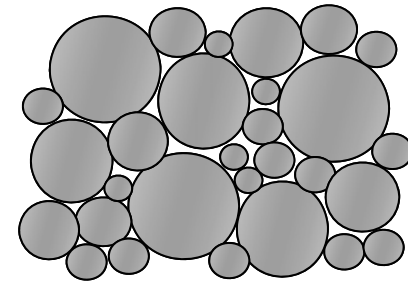
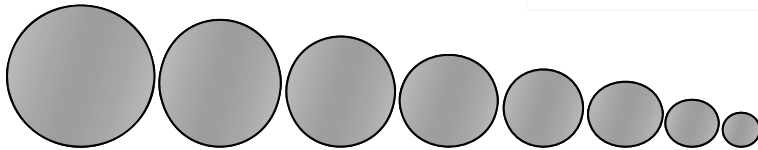

**Gap-Graded**

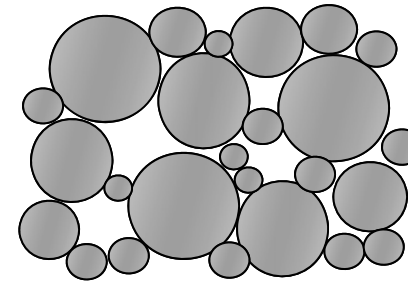
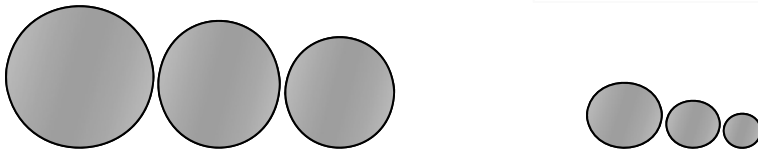

**Uniformly-Graded**

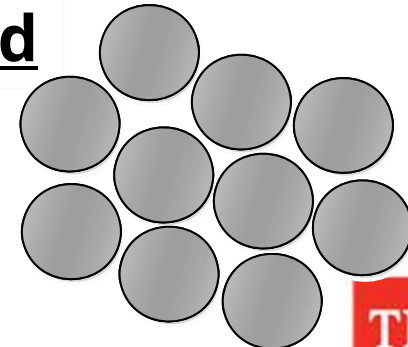
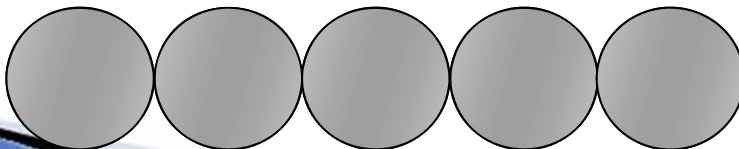



# Field Sample Size

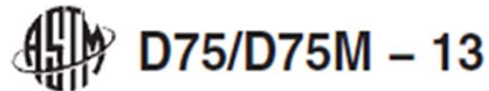

TABLE 1 Minimum Size of Field Samples

Aggregate Size <sup>A</sup>	Field Sample Mass, min, kg <sup>B</sup> [lb]	Field Sample Volume, min, L [gal]
Fine Aggregate		
2.36 mm [No. 8]	10 [22]	8 [2]
4.75 mm [No. 4]	10 [22]	8 [2]
Coarse Aggregate		
9.5 mm [3/8 in.]	10 [22]	8 [2]
12.5 mm [1/2 in.]	15 [35]	12 [3]
19.0 mm [3/4 in.]	25 [55]	20 [5]
25.0 mm [1 in.]	50 [110]	40 [10]
37.5 mm [1 1/2 in.]	75 [165]	60 [15]
50 mm [2 in.]	100 [220]	80 [21]
63 mm [2 1/2 in.]	125 [275]	100 [26]
75 mm [3 in.]	150 [330]	120 [32]
90 mm [3 1/2 in.]	175 [385]	140 [37]

# Test Sample Size

7.4 *Coarse Aggregate*—The size of the test sample of coarse aggregate shall conform with the following:

Nominal Maximum Size, Square Openings, mm (in.)	Test Sample Size, min, kg (lb)
9.5 ( $\frac{3}{8}$ )	1 (2)
12.5 ( $\frac{1}{2}$ )	2 (4)
19.0 ( $\frac{3}{4}$ )	5 (11)
25.0 (1)	10 (22)
37.5 ( $1\frac{1}{2}$ )	15 (33)
50 (2)	20 (44)
63 ( $2\frac{1}{2}$ )	35 (77)
75 (3)	60 (130)
90 ( $3\frac{1}{2}$ )	100 (220)

## Dry the Material

- Dry the aggregate to a constant mass in an oven at  $110 \pm 5^{\circ}\text{C}$  ( $230 \pm 9^{\circ}\text{F}$ )
- Allow the material to cool



and Aggregate Technician Certification

## Determine the Sample Mass

- Weigh the sample to the nearest 0.1 of a unit of the original sample mass



and Aggregate Technician Certification

# Sieves

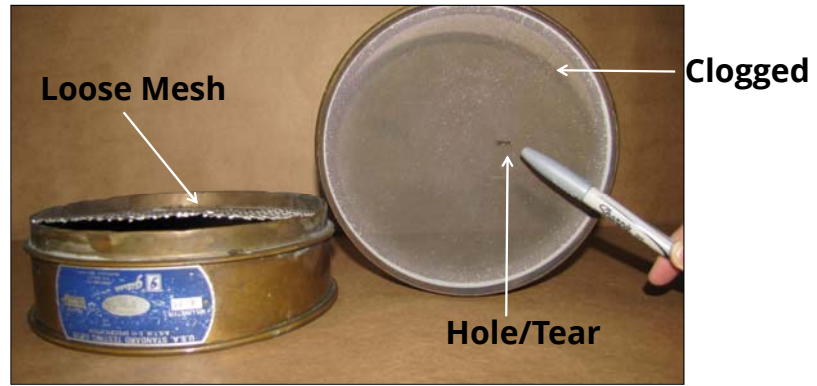

# Maximum Loading of Sieves

**TABLE 1 Maximum Allowable Quantity of Material Retained on a Sieve, kg**

Sieve Opening Size, mm	Nominal Dimensions of Sieve <sup>A</sup>				
	203.2-mm dia <sup>B</sup>	254-mm dia <sup>B</sup>	304.8-mm dia <sup>B</sup>	350 by 350 mm	372 by 580 mm
	Sieving Area, m <sup>2</sup>				
	0.0285	0.0457	0.0670	0.1225	0.2158
125	C	C	C	C	67.4
100	C	C	C	30.6	53.9
90	C	C	15.1	27.6	48.5
75	C	8.6	12.6	23.0	40.5
63	C	7.2	10.6	19.3	34.0
50	3.6	5.7	8.4	15.3	27.0
37.5	2.7	4.3	6.3	11.5	20.2
25.0	1.8	2.9	4.2	7.7	13.5
19.0	1.4	2.2	3.2	5.8	10.2
12.5	0.89	1.4	2.1	3.8	6.7
9.5	0.67	1.1	1.6	2.9	5.1
4.75	0.33	0.54	0.80	1.5	2.6

<sup>A</sup> Sieve frame dimensions in inch units: 8.0-in. diameter; 10.0-in. diameter, 12.0-in. diameter; 13.8 by 13.8 in. (14 by 14 in. nominal); 14.6 by 22.8 in. (16 by 24 in. nominal).

<sup>B</sup> The sieve area for round sieve frames is based on an effective diameter 12.7 mm (½ in.) less than the nominal frame diameter, because Specification E11 permits the sealer between the sieve cloth and the frame to extend 6.35 mm (¼ in.) over the sieve cloth. Thus the effective sieving diameter for a 203.2-mm (8.0-in.) diameter sieve frame is 190.5 mm (7.5 in.). Sieves produced by some manufacturers do not infringe on the sieve cloth by the full 6.35 mm (¼ in.).

<sup>C</sup> Sieves indicated have less than five full openings and should not be used for sieve testing except as provided in 8.6.



## Overloaded Sieve



### Options for Overloading

- Use larger sieve
- Portion the sample
- Place another sieve in the nest



and Aggregate Technician Certification

## Mechanical Shaker

- Use a mechanical shaker to agitate the sieves



and Aggregate Technician Certification

## Weighing

- Weigh the sample to the nearest 0.1 of a unit of the original sample mass



## Sample Problem #1

Original Sample Mass (g)		507.8
Sieve Size or Designation		Individual Weight Retained (g)
4.75 mm	No. 4	0.0
2.36 mm	No. 8	51.0
1.18 mm	No. 16	98.0
600 um	No. 30	106.0
300 um	No. 50	117.0
150 um	No. 100	95.0
75 um	No. 200	29.0
< 75 um	< No. 200	11.0
Total		

## Sample Problem #1

$$\text{AASHTO Loss} = \frac{\text{Original Sample Mass} - \text{Sum of Individual Wt.}}{\text{Original Sample Mass}} \times 100$$

$$\text{AASHTO Loss} =$$



# Sample Problem # 1

Original Sample	507.8
-----------------	-------

Sieve Size or Designation		Individual Weight Retained (g)	Individual Percent Retained	Cumulative Percent Retained	Cumulative Percent Passing
4.75 mm	No. 4	0.0			
2.36 mm	No. 8	51.0			
1.18 mm	No. 16	98.0			
600 µm	No. 30	106.0			
300 µm	No. 50	117.0			
150 µm	No. 100	95.0			
75 µm	No. 200	29.0			
< 75 µm	< No. 200	11.0			

## Fineness Modulus

- Numerical value to indicate fineness of aggregate
- Aggregate with same fineness modulus will require the same quantity of water to produce a mix of the same consistency and strength
- Higher fineness modulus means material is more coarse
- Cumulative percent retained on No. 100, No. 50, No. 30, No. 16, No. 8, No. 4, 3/8 inch, 3/4 inch, 1 1/2 inch and 3 inch sieves (Divide by 100)



## Fineness Modulus

Sieve	Cumulative Percent Retained
3 in	
1 1/2 in	
3/4 in	
3/8 in	
No. 4	
No. 8	
No. 16	
No. 30	
No. 50	
No. 100	
Total	
FM	

Soils and Aggregate Technician Certification

## Sample Problem #2

Original Sample Mass (g)		91.2
Sieve Size or Designation		Individual Weight Retained (g)
75 mm	3 in	0.0
50 mm	2 in	0.0
37.5 mm	1 1/2 in	6.0
25 mm	1 in	20.0
19 mm	3/4 in	16.0
12.5 mm	1/2 in	13.0
9.5 mm	3/8 in	28.0
4.75 mm	No. 4	8.0
< 4.75 mm	< No. 4	0.0
Total		

## Sample Problem #2

$$\text{AASHTO Loss} = \frac{\text{Original Sample Mass} - \text{Sum of Individual Weights}}{\text{Original Sample Mass}} \times 100$$

$$\text{AASHTO Loss} =$$

# Sample Problem # 2

Original Sample	91.2
-----------------	------

Sieve Size or Designation		Individual Weight Retained	Individual Percent Retained	Cumulative Percent Retained	Cumulative Percent Passing
75 mm	3 in	0.0			
50 mm	2 in	0.0			
37.5 mm	1 1/2 in	6.0			
25 mm	1 in	20.0			
19 mm	3/4 in	16.0			
12.5 mm	1/2 in	13.0			
9.5 mm	3/8 in	28.0			
4.75 mm	No. 4	8.0			
< 4.75 mm	< No. 4	0.0			

## Fineness Modulus

Sieve	Cumulative Percent Retained
3 in	
1 1/2 in	
3/4 in	
3/8 in	
No. 4	
No. 8	
No. 16	
No. 30	
No. 50	
No. 100	
Total	
FM	



and Aggregate Technician Certification



# 6

## **Embankments and Embankment Materials**

# Embankments and Embankment Materials

## References



TDOT Standard Specifications  
(Section 205)  
DT - Forms



## Preparation of Embankment Areas Inspection Checklist

- Clearing and grubbing (removal of vegetation) satisfactorily performed
- Depressions or holes below the original ground are filled and compacted with suitable material before lifts are placed
- Compacted road surfaces containing granular materials within 3 feet of the subgrade are scarified to a depth of 6 inches and re-compacted



## Preparation of Embankment Areas Inspection Checklist

- Concrete pavements and bases are removed and broken
- Embankment material must be placed in lifts
- Lifts are not placed on surfaces which are frozen or contain snow, mud or ice



## Preparation of Embankment Areas Inspection Checklist

Where the original ground surface is less than three feet below the subgrade, the following apply:

- All sod and vegetation is removed
- Unsuitable material is replaced with suitable material
- The cleared surface is broken up to a depth of six inches and re-compacted
- Cultivated sod not required to be removed before constructing the embankment
- Compacted road surface containing granular materials lies within 3 feet of subgrade, scarify at least 6 inches and re-compact the scarified material



## Major Embankment Materials

- Rock fragments
- Gravel
- Sand
- Silt
- Clay



and Aggregate Technician Certification



# Form DT-0332 Proctor Density Report

Original to:  
Headquarters Materials and Tests  
Copies to:  
Regional Materials and Tests  
Project Supervisor



STATE OF TENNESSEE  
DEPARTMENT OF TRANSPORTATION  
DIVISION OF MATERIALS AND TESTS  
6401 CENTENNIAL BLVD.  
NASHVILLE, TENNESSEE 37243-8360

**SAMPLE**

PROCTOR DENSITY REPORT

Project Reference No. SP County Davidson Region 3  
 Project No. 12345-6789-10 Contract No. 5678  
 Material Soil Submitted by Williams  
 Report No. 345 Date Sampled 27-Sep-03  
 Serial No. S-123 Date Reported 02-Oct-03  
 Contractor James Bros Sampled By Jim Walters  
 Project Supervisor Smith Sampled From Fieldway

GRADATION - TOTAL PERCENT PASSING			
Sample No.	1-G	2-G	3-G
Station	229+75	232+00	231+90
Depth, ft.	2	3	2
Location, ft.	12' R	12' L	12' L
2"			
1-1/2"			
1"			
3/4"		100	100
3/8"		95	92
No. 4	100	87	89
No. 10	85	84	76
No. 16	76	80	65
No. 40	29	25	15
No. 100	8	10	9
No. 200	3.0	2.0	1.5
Silt and Clay			
Clay			
SOIL CONSTANTS			
Liquid Limit	30	25	23
Plastic Limit	19	20	18
Plasticity Index	11	5	5
Type	Granular Material	Granular Material	Granular Material
Group	A-2-6(0)	A-2-4(0)	A-2-4(0)
DENSITY CORRECTED FOR 14 MATERIAL			
Proctor Density	100.0	102.5	101.5
Optimum Moisture	19.0	22.5	19.0
95 % Density	95.0	97.4	96.4
Moisture Range Above Subgrade			
Moisture Range Below Subgrade			

Approved for information only

Regional Materials and Tests

Engineer of Materials and Tests

Form DT-0332 Rev. 10-01

# Gradation

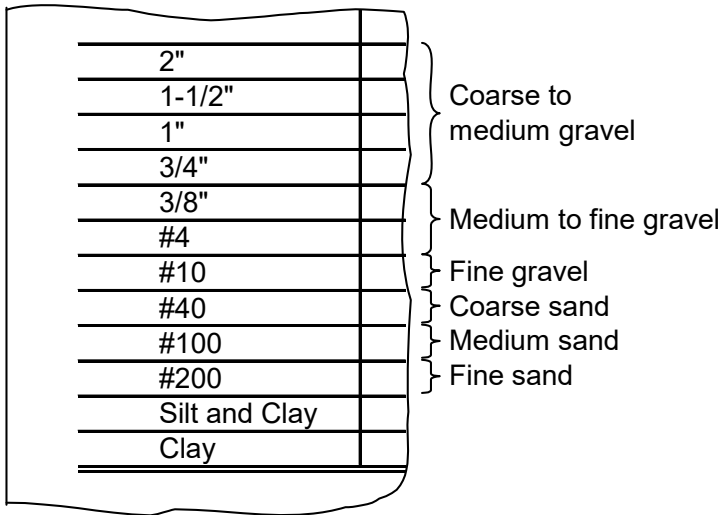
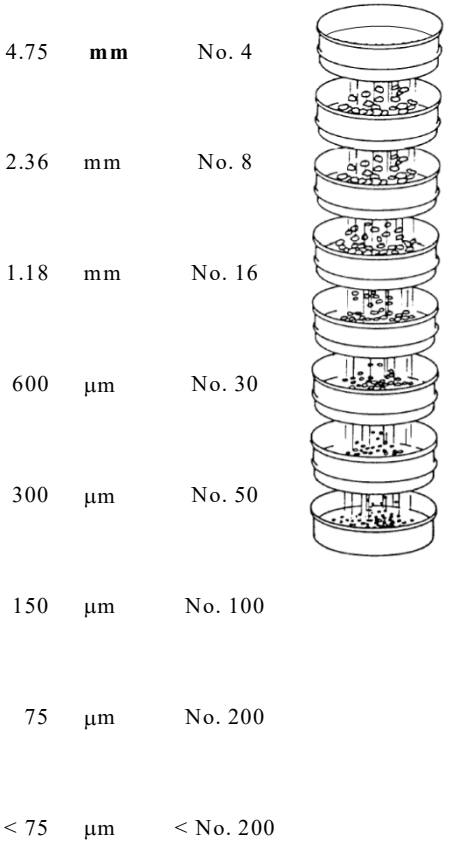

# Gradation

## (Grain Size Distribution)

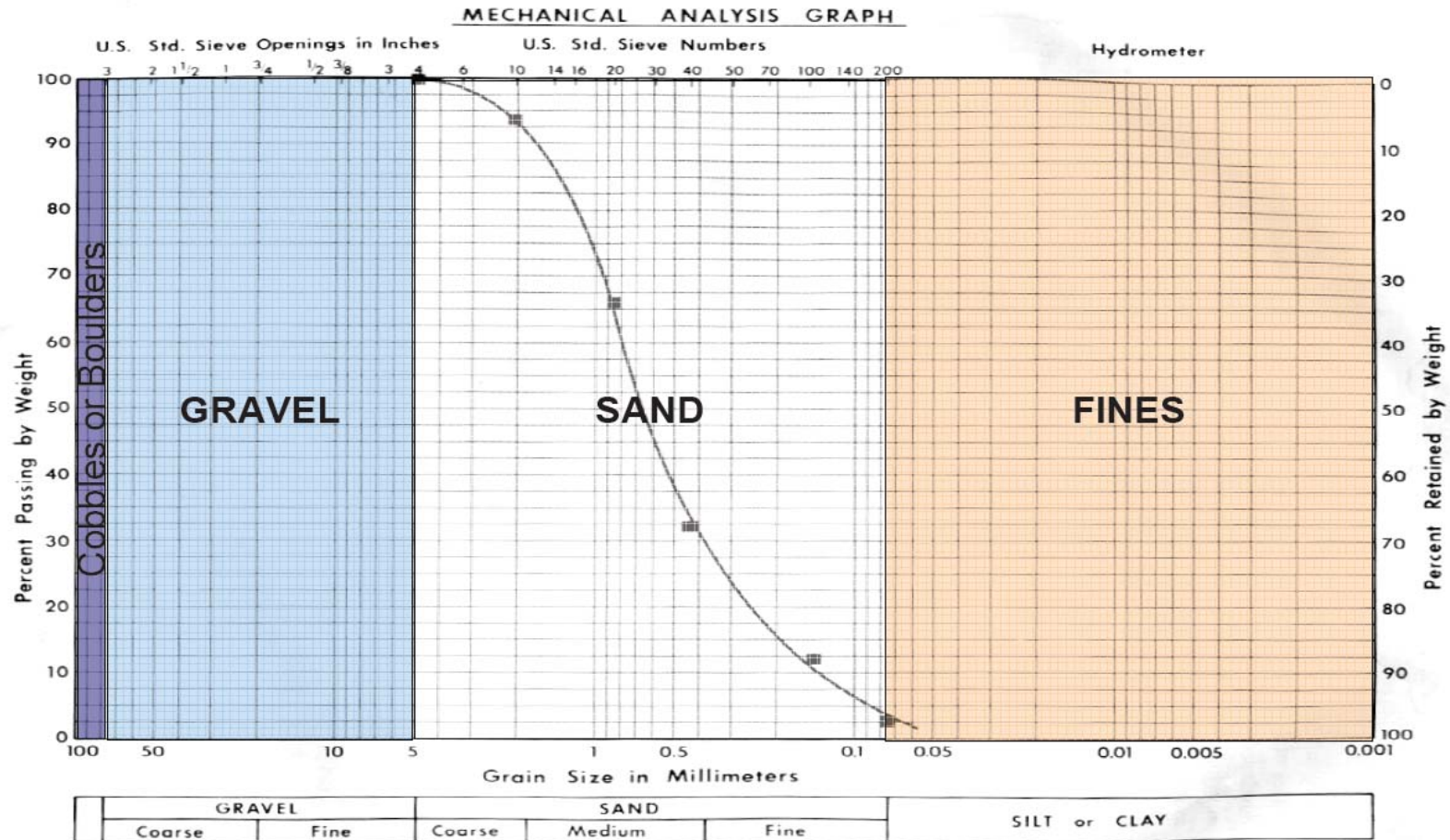

# Gradation Example

Original to: Headquarters Materials and Tests  
Copies to: Regional Materials and Tests  
Project Supervisor



**STATE OF TENNESSEE  
DEPARTMENT OF TRANSPORTATION  
DIVISION OF MATERIALS AND TESTS  
6491 CENTENNIAL BLVD.  
NASHVILLE, TENNESSEE 37243-4368**

**PROCTOR DENSITY REPORT**

Project Reference No. \_\_\_\_\_ County MCMINN Region 2  
Project No. 54000-1500-04 Contract No. \_\_\_\_\_  
Material Soil Project Supervisor \_\_\_\_\_  
Report No. \_\_\_\_\_ Date Sampled 04-Jan-03  
Serial No. S-3 Date Reported 09-Jan-03  
Contractor \_\_\_\_\_ Sampled By \_\_\_\_\_  
Producer \_\_\_\_\_ Sampled From \_\_\_\_\_

GRADATION - TOTAL PERCENT PASSING						
Sample No.	1-A	2-A	3-A	4-A	5-A	6-A
Station	21+50	27+00	27+00	27+00	23+00	32+00
Depth, ft.	0"-5"	0"-8"	8"-17"	0"-3"	0"-13"	0"-8"
Location, ft.	C/L	60' Lt. C/L	60' Lt. C/L	C/L	30' Lt. C/L	C/L
2"						
1-1/2"						
1"						
3/4"		100	100			100
3/8"		98	93	100	100	97
No. 4	100	93	84	96	97	88
No. 10	99	86	76	94	91	83
No. 16	99	82	55	89	82	71
No. 40	98	77	48	86	78	63
No. 100	98	74	45	86	76	63
No. 200	98.0	74.0	45.0	86	76	60
Silt and Clay	98	74	45	86	76	60
Clay	74	39	18	54	45	26



and Aggregate Technician Certification

# Soil Constants

Original to: Headquarters Materials and Tests  
Copies to: Regional Materials and Tests  
Project Supervisor



**STATE OF TENNESSEE  
DEPARTMENT OF TRANSPORTATION  
DIVISION OF MATERIALS AND TESTS  
6491 CENTENNIAL BLVD.  
NASHVILLE, TENNESSEE 37243-4368**

**PROCTOR DENSITY REPORT**

Project Reference No. \_\_\_\_\_ County MCMINN Region 2  
Project No. 54000-1500-04 Contract No. \_\_\_\_\_  
Material Soil Project Supervisor \_\_\_\_\_  
Report No. \_\_\_\_\_ Date Sampled 04-Jan-03

SOIL CONSTANTS						
Liquid Limit	60	51	28	54	50	34
Plastic Limit	40	24	17	25	29	22
Plasticity Index	20	27	11	29	21	12
Calculated PI	20	22	6	26	17	9
Type	A-7-5	A-7-6	A-6	A-7-6	A-7-6	A-6
Group	27	20	2	27	17	5
DENSITY CORRECTED FOR +4 MATERIAL						
Proctor Density	85.5	98.5	117.5	97.5	87.0	105.0
Optimum Moisture	33.0	22.5	12.5	22.0	25.0	17.5
95 % Density	81.2	93.6	111.6	92.6	92.2	99.8
Moisture Range Above Subgrade	30-37.5	19.5-25.5	10-15.5	20-24.5	19-25	15.5-20.5
Moisture Range Below Subgrade						

Regional Materials and Tests  
Approved for Information Only \_\_\_\_\_  
Engineer of Materials and Tests



and Aggregate Technician Certification

# Consistency

- Atterberg limits are measures of moisture content at which the soil changes physical states
  - shrinkage limit
  - plastic limit
  - liquid limit
  - plasticity index
- Soil constants indicate the load-carrying capacity of the embankment material
- They are based on the water-holding capacity of soils under various conditions and are expressed as a moisture percentage

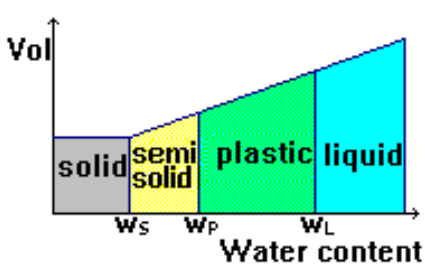

$$w = \frac{(\text{wet soil weight}) - (\text{oven - dry soil weight})}{(\text{oven - dry soil weight})} \times 100$$

Soil and Aggregate Technician Certification

# Shrinkage Limit

- Shrinkage limit is the moisture content below which a soil will no longer change volume

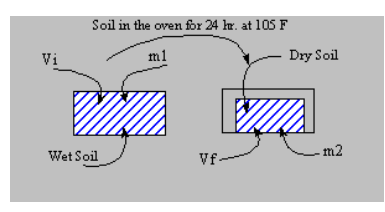

Soil and Aggregate Technician Certification

# Plastic Limit

- Plastic limit is the moisture content at which a soil passes from a semisolid to a plastic state
- Plastic limit is influenced by the clay content of a soil
- Sand is a nonplastic material
- Reduction of moisture content below the P.L. leads to a rapid increase in load-carrying capacity
- Increased moisture content above the P.L. leads to a rapid decrease in load-carrying capacity

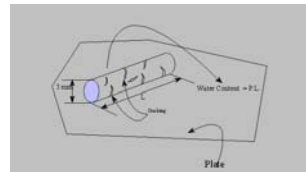

and Aggregate Technician Certification

# Liquid Limit

- Liquid limit is the moisture content at which a soil passes from a plastic to a liquid state
- High liquid limits indicate soils of high clay content and low load-carrying capacity

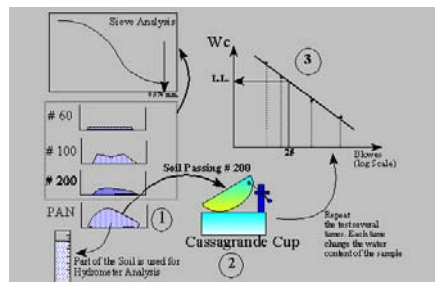

and Aggregate Technician Certification



## Plasticity Index

- Plasticity index is the moisture content range at which a soil is in a plastic state
- The plasticity index is the numerical difference between the liquid limit and the plastic limit  
 Given: LL = 56, PL = 37  
 $PI = 56 - 37 \rightarrow PI = 19$
- Low P.I. Values (<10) indicate that a soil will go from its P.L. to its L.L. with small additions of water
- High P.I. Values (>20) indicate that a considerable amount of water can be added to a soil before it will go from its P.L. to its L.L.
- If L.L. < P.L., the material is considered nonplastic (N.P.)

Soils and Aggregate Technician Certification



## Calculated Plasticity Index

- The calculated P.I. is significant when the material contains large amounts of granular particles
- It relates the P.I. to the total sample rather than just the < 40 material
- The calculated P.I. is determined as follows:

$$P.I._{calculated} = \frac{P.I._{actual} \times \text{material passing \#40 sieve}}{100}$$

Soils and Aggregate Technician Certification





# AASHTO Soil Classification

AASHTO Recommended Practice for Classification of Soils and Soil-Aggregate Mixtures												
General Classification	Granular materials (≤ 35 percent of total sample passing No. 200)						Silt-clay materials (> 35 percent of total sample passing No. 200)					
Group Classification	A-1		A-3	A-2				A-4	A-5	A-6	A-7	
Subgroup	A-1-a	A-1-b		A-2-4	A-2-5	A-2-6	A-2-7				A-7-5	A-7-6
Sieve Analysis, percent passing												
No. 10 .....	≤ 50											
No. 40 .....	≤ 30	≤ 50	≥ 51									
No. 200, F .....	≤ 15	≤ 25	≤ 10									
Characteristics of fraction passing 0.425 mm (No. 40)												
Liquid Limit, LL .....				≤ 40	≥ 41	≤ 40	≥ 41	≤ 40	≥ 41	≤ 40	≥ 41	≥ 41
Plasticity Index, PI .....	≤ 6		NP	≤ 10	≤ 10	≥ 11	≥ 11	≤ 10	≤ 10	≥ 11	≤ (LL-30)	> (LL-30)
Group Index, GI .....	0		0	0		≤ 4		≤ 8	≤ 12	≤ 16	≤ 20	

# AASHTO Soil Classification

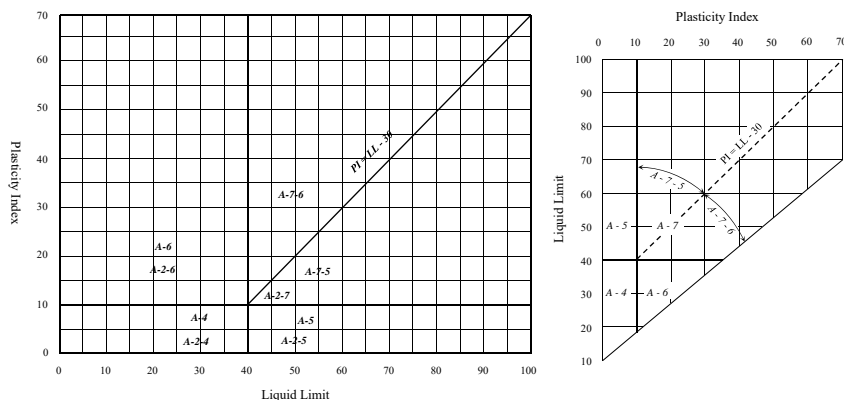

Soils and Aggregate Technician Certification



## Group A-1

- Usually well-graded mixture of coarse to fine particles.
- They may have soil binders.
- Soils in Group A-1 are the best embankment material.
- They have stable load-carrying capacities regardless of their moisture contents.
  - Subgroup A-1-a is predominantly stone fragments or gravel
  - Subgroup A-1-b is predominantly coarse sand



Soils and Aggregate Technician Certification



## Group A-2

- Includes a variety of granular materials which are borderline between Groups A-1 and A-3, and silt-clay materials
- Stable when dry but may be subject to frost damage
- Soils in Group A-2 can generally be used for blanketing plastic subgrades of some silty or clayey materials to prevent moisture (capillary water) from creeping to the pavement course
  - Subgroups A-2-4 and A-2-5 are satisfactory base course materials when properly compacted; they are usually granular materials with silty or loamy soil-binder characteristics of Groups 4 and 5.
  - Subgroups A-2-6 and A-2-7 are usually granular materials with clay or loamy soil-binder characteristics of Groups 6 and 7. These soils may lose their stability under capillary action or from lack of proper drainage.



Soils and Aggregate Technician Certification

## Group A-3

- Consists of sands with limited coarse materials or soil binders.
- Examples of this group are fine desert sand, fine beach sand and stream-deposited sand.
- These soils make suitable subgrades when confined and damp, but are subject to erosion.
- They can be compacted by vibratory, pneumatic-tire and steel-wheel rollers, but not with sheepsfoot rollers.



Soils and Aggregate Technician Certification

## Group A-4

- Consists of common silty soils with textures varying from sandy loams to silty and clayey loams.
- These soils have an affinity for water and will swell and lose considerable stability unless properly compacted and drained.
- Silty loams are often difficult to compact--pneumatic rollers usually are needed for proper compaction.
- Careful field control of moisture content is required.



and Aggregate Technician Certification



## Group A-5

- Similar to A-4 but the soils are more elastic with higher liquid limit.



and Aggregate Technician Certification



## Group A-6

- Consist of soils which usually have high volume changes between wet and dry states.
- If moisture content is properly controlled, they will compact readily under a sheepsfoot roller or a pneumatic-tired roller.
- These soils will compress when wet and shrink and swell with changes in moisture content.
- A-6 soils do not drain readily.



Soils and Aggregate Technician Certification



## Group A-7

- Similar to A-6, except that the soils may be elastic as well as subject to considerable volume changes.
- Soils in Group A-7 are not preferred as embankment materials.
  - Subgroup A-7-5 soils usually have moderate P.I.s in relation to their L.L.s. These soils are highly elastic and subject to high volume changes.
  - Subgroup A-7-6 soils have high P.I.s in relation to their L.L.s. These soils are highly elastic and subject to higher volume changes than A-7-5 soils.



Soils and Aggregate Technician Certification



# Group Index

- Group refers to the Group Index rating.
- It is based on gradation, liquid limit, and plasticity index of the material.
- It allows a within-group evaluation of the clayey granular materials and the silt-clay materials in the AASHTO classification.
- If the group index is known, the material can be rated within the AASHTO groups.
- The lower value of the index indicates better grades of material within the same group.



and Aggregate Technician Certification

# Group Index

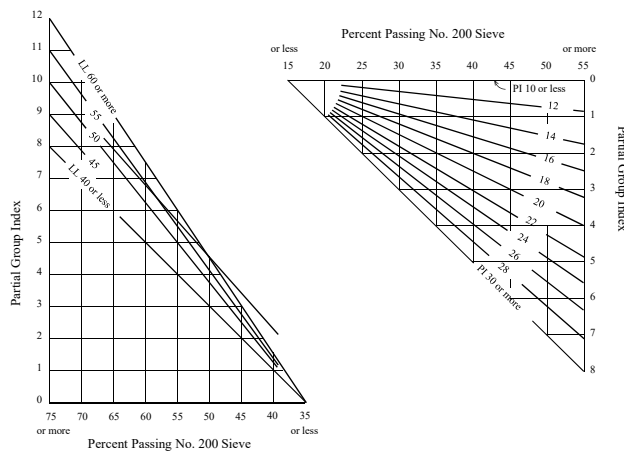

and Aggregate Technician Certification



# 7

## **Compaction and Density Concepts**



## Compaction and Density Concepts



## Compaction - Definition

- Compaction is the process of mechanically densifying a soil.
- Densification is accomplished by pressing the soil particles together into a close state of contact with air being expelled from the soil mass in the process.



## Compaction - Definition (cont'd)

- Compaction, as used here, implies dynamic compaction or densification by the application of moving loads to the soil mass.
- In relation to compaction, the density of a soil is normally expressed in terms of ***dry density or dry unit weight***. Occasionally, the wet density or wet unit weight is used.
- These values are typically described in a number of pounds per cubic foot (lb/ft<sup>3</sup>)



and Aggregate Technician Certification

## Soil Properties Affected by Compaction

- Settlement
- Shearing resistance
- Movement of water
- Volume change



and Aggregate Technician Certification

## Settlement

- Consolidation is minimized by compaction
- Closer arrangement of soil particles

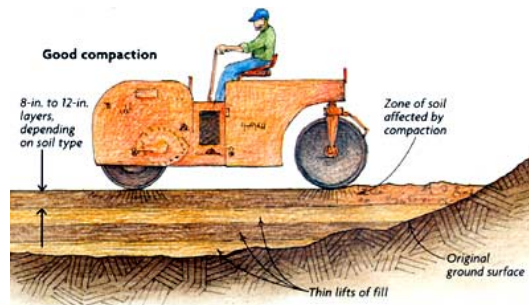

and Aggregate Technician Certification

## Shearing Resistance

- Compaction increases shearing resistance which may allow
  - a thinner pavement structure
  - steeper side slopes



and Aggregate Technician Certification

## Movement of Water

- Compaction reduces
  - number of voids
  - size of void spaces
  - Permeability
  - seepage of water
  - Movement of capillary water

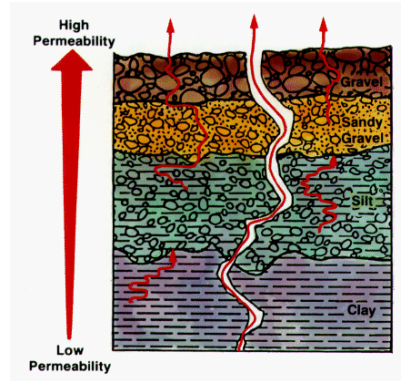

Soils and Aggregate Technician Certification

## Volume Change

- Compaction minimizes
  - Shrinkage
  - swelling



Soils and Aggregate Technician Certification

## Earthwork Requiring Moisture-Density Tests

Embankments

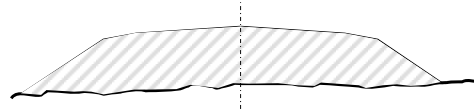

Pipe backfill

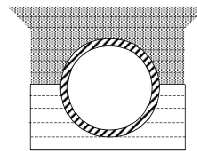

Pipe backfill

Structure backfill

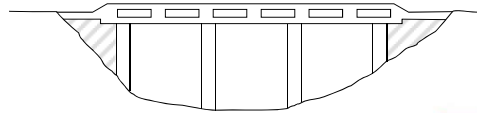

Soil and Aggregate Technician Certification

## Moisture-Density Tests

- TDOT uses the Proctor density test to determine the densities to which a soil can be compacted with various moisture contents
- The highest density obtained is called the maximum density (Proctor density) and the corresponding moisture content is called the optimum moisture



Soil and Aggregate Technician Certification

## Density Ranges

- High maximum densities will range from 125 to 145 pounds per cubic foot, oven-dry weight
- Low maximum densities will range from 85 to 100 pounds per cubic foot, oven-dry weight

## Moisture Ranges

- A low optimum moisture corresponds to a high maximum density and will be around 8 percent
- A high optimum moisture corresponds to a low maximum density and will be around 30 percent

## AASHTO T99 & T180

- AASHTO T99 Standard Proctor Test
- AASHTO T180 Modified Proctor Test
  - prescribes a compacting force and procedure that closely approximates densities that can be obtained on soils in the field with tamping rollers



Soils and Aggregate Technician Certification

## Proctor Density Test

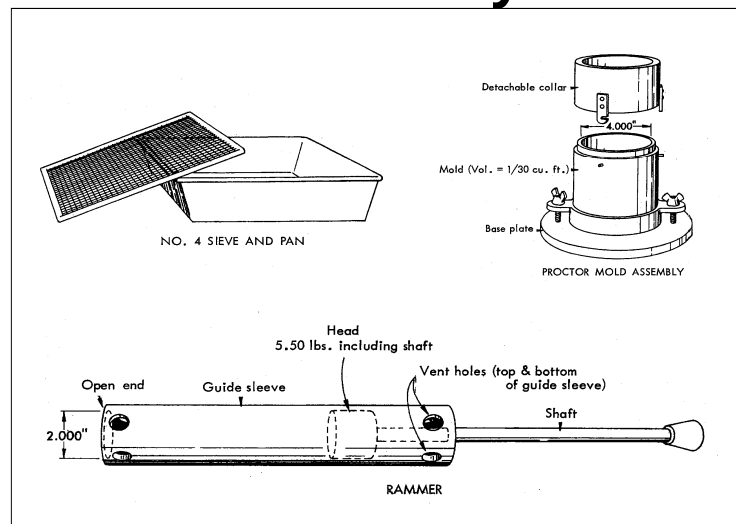

Soils and Aggregate Technician Certification

## Proctor Density Test



and Aggregate Technician Certification

## Proctor Density Test



and Aggregate Technician Certification



# Compaction Theory

- When dry densities of the sample are determined and plotted as a function of moisture content, the curve is called a compaction curve.
- The peak of the curve represents the maximum dry density at the optimum moisture content

Figure 1. Typical moisture density relationships or compaction curves

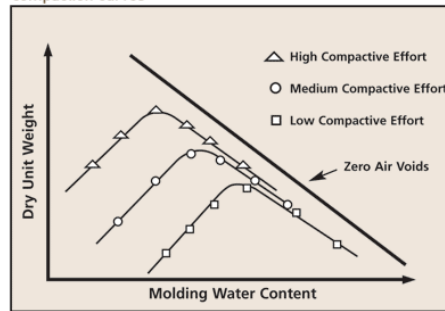

# Moisture-Density Curve

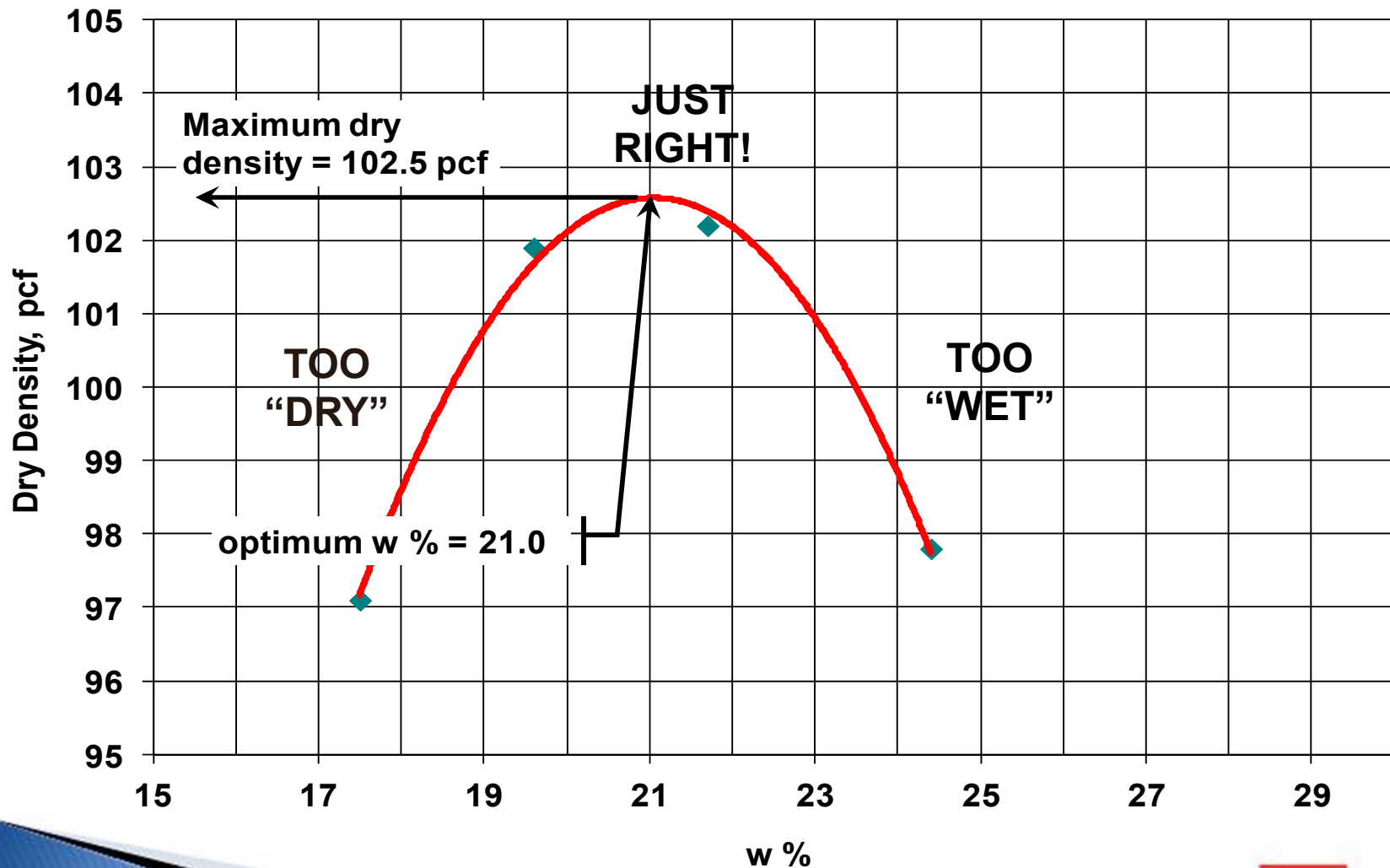



# 8

## **Embankment Placement**

# Embankment Placement



## Organic Materials

- Topsoil or other organic material should never be used as embankment material

WHY?



## Sources of Embankment Materials

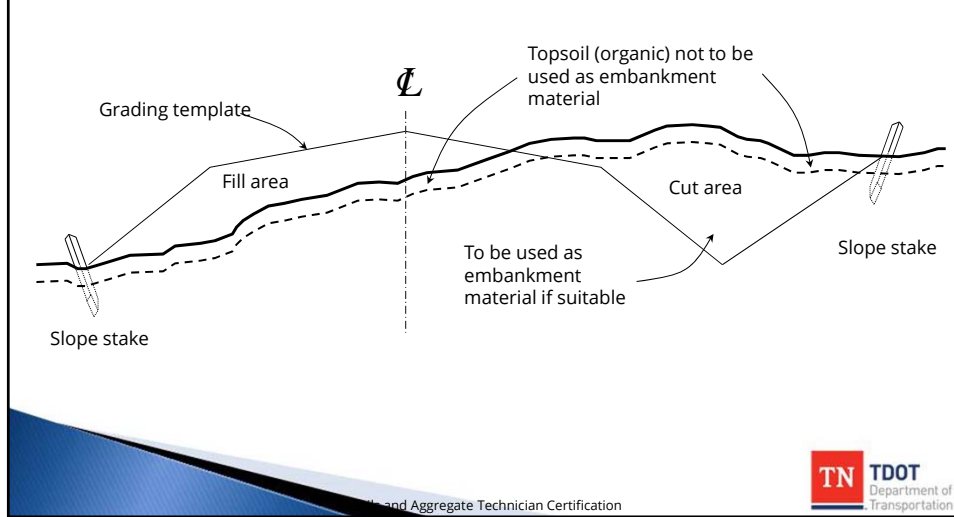

## Earthwork Balances

- Embankments are typically designed to achieve earthwork balances at intervals along the project
- The contractor is expected to haul within the balances shown on the plans or as adjusted by the project supervisor

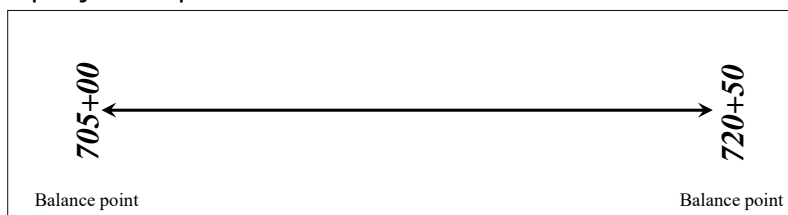

## Equipment for Placement

- The embankment is placed on natural ground usually by scrapers used for excavation or by trucks if the haul distance is long
- It is spread and leveled in specified lifts



and Aggregate Technician Certification

## Placement Equipment and Procedures

- The equipment and procedures involved in the dumping and spreading of the embankment material will depend on:
  - the type of equipment available
  - the type of material used
- Embankments must be built up in uniform, well-mixed layers for the full width of the roadway
- The contractor must have enough equipment and use procedures that will enable proper moisture and compaction requirements to be met



and Aggregate Technician Certification

# Embankment Placement

Standard Specifications Section 205.04

- Perishable materials, such as stumps and brush, are not buried in the embankment
- Crowns are maintained
- Individual lifts do not exceed 10 inches before compaction
  - When excavated material consists predominantly of rock fragments that are too large to place in 10-inch lifts, the material may be placed in the embankment in layers not exceeding 3 feet
  - All rock to be placed in the embankment is broken into sizes not exceeding 2 feet in the maximum dimension and each of these rock lifts is leveled and smoothed with finer material
- The embankment is built up evenly and uniformly
- Embankments are constructed with similar materials



and Aggregate Technician Certification

# Compaction of Embankments

Standard Specifications Section 205.04

- Embankments that consist of predominantly fine-grained soil must be placed in horizontal lifts not thicker than 10 inches before compaction
- Each layer, excluding the top 6 inches of the roadbed must be compacted to a density not less than 95 percent of maximum density

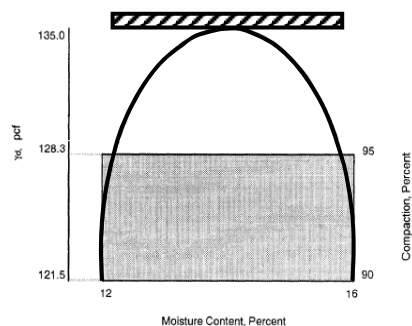

and Aggregate Technician Certification



# Compaction of Embankments

Standard Specifications Section 205.04

- When a minimum of 95 percent maximum density is required, the moisture content of the material must be within the range of values at which this density can be obtained

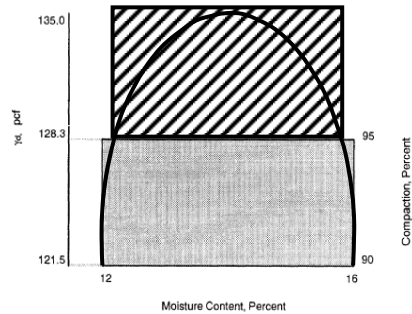

and Aggregate Technician Certification

# Compaction of Embankments

Standard Specifications Section 205.04

- When a 100 percent maximum density is required, the moisture content of the material must not vary from optimum moisture by more than 3 percentage points

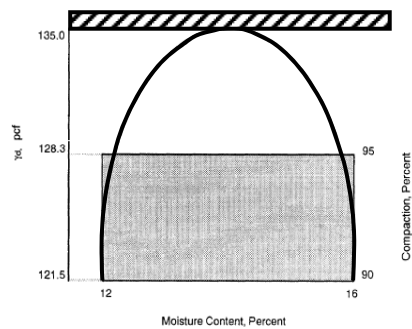

and Aggregate Technician Certification

# Compaction of Embankments

Standard Specifications Section 205.04

- The contractor is required to aerate the material or distribute and incorporate water uniformly to control moisture content within appropriate limits
- If the moisture is within the appropriate limits but the density is not, additional compaction is necessary

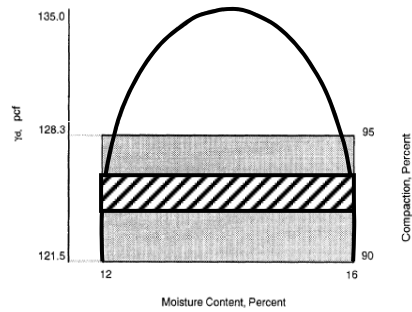

and Aggregate Technician Certification

# Top Six Inches Specifications

Standard Specifications Subsection 205.04

- In both cut and fill sections, the top six inches of roadbed must be compacted to 100 percent of maximum density

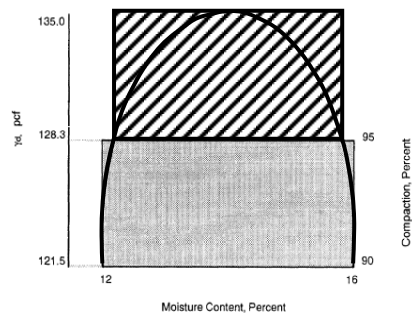

and Aggregate Technician Certification

## Base Compaction

Standard Specifications Subsection 303.10

- Thickness of layers must be within limits that allow proper compaction
- In general, the limit is 4 to 8 inches, depending on
  - material
  - method of construction
- Smooth-wheeled or vibratory rollers are recommended for compacting hard, angular materials with limited fines



and Aggregate Technician Certification

## Type A Base Specifications

Standard Specifications Subsection 303.10

- An average of 100 percent of maximum density is specified
- No individual test less than 97 percent of maximum density
- A 3 percent range (from optimum moisture content) is specified for moisture

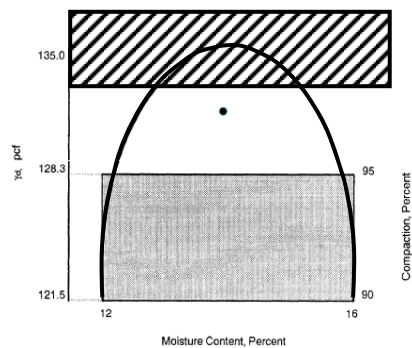

and Aggregate Technician Certification

## Type B Base Specifications

Standard Specifications Subsection 303.10

- An average of 97 percent of maximum density is specified
- No individual test less than 95 percent of maximum density
- A 3 percent range (from optimum moisture content) is specified for moisture

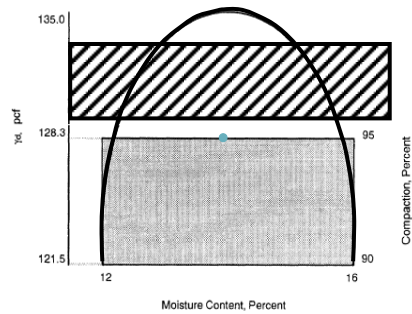

## Compaction of Embankments

- Rollers are used to obtain the required densities and should be operated continuously while embankment materials are being placed

## Sheepsfoot Roller

- Compacts all fine-grained materials
- Will not compact cohesionless granular materials
- Compacts from the bottom up and is used especially for plastic materials
- The lift thickness for sheepsfoot rollers is limited to 6 inches in compacted depth
- If the required densities are not being obtained, it is often necessary to change to a thinner lift to ensure that the specified density is obtained



Roller Feet Embedded to Within 2 Inches of the Drum

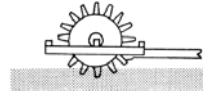

Roller After it has "Walked Out"

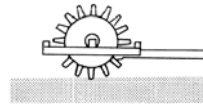

and Aggregate Technician Certification

## Tamping-Foot Roller

- A tamping-foot roller is a modification of the sheepsfoot roller
- The tamping feet are trapezoidal pads attached to a drum
- Tamping-foot rollers are normally self-propelled, and the drum may be capable of vibrating
- The tamping-foot roller is suitable for use with a wide range of soil types



and Aggregate Technician Certification

## Steel-Wheeled Roller

- The steel-wheeled roller is much less versatile than the pneumatic roller
- Although extensively used, it is normally operated in conjunction with one of the other types of compaction rollers
- It is used for compacting granular materials in thin lifts
- Probably its most effective use in subgrade work is in the final finish of a surface, following immediately behind the blade, forming a dense and watertight surface



and Aggregate Technician Certification

## Self-Propelled, Smooth-Drum Vibratory Roller

- Compacts with a vibratory action that rearranges the soil particles into a denser mass
- The best results are obtained on cohesionless sands and gravels
- Compaction efficiency is impacted by the ground speed of the roller and the frequency and amplitude of the vibrating drum



and Aggregate Technician Certification

## Pneumatic Rollers

- Variants include
  - pneumatic-tired roller
  - self-propelled pneumatic-tired roller
- Suitable for granular materials; however, it is not recommended for fine-grained clay soils except as necessary for sealing the surface after a sheepfoot roller has “walked out”
- It compacts from the top down and is used for finishing all types of materials, following immediately behind the blade and water truck



and Aggregate Technician Certification

## Pneumatic Rollers

- Pneumatic rollers have an uneven number of wheels and should never have fewer than 7 wheels. The tires are arranged so that the gaps between the tires of one axle will be covered by the tires of the other.

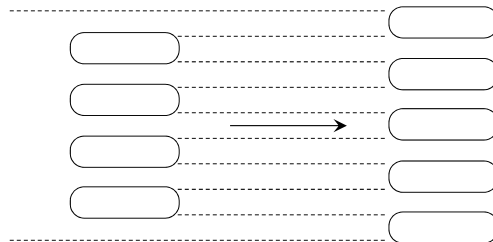

and Aggregate Technician Certification

## Corrective Actions

- Overcompaction
- Undercompaction
- Too Wet
- Too Dry

## Overcompaction

- Occurs when material is densified in excess of specified range
- The material may be stronger than required, which indicates
  - wasted construction effort
  - sheared material



## Undercompaction

- Undercompaction may indicate
  - A missed roller pass
  - Insufficient roller weight
  - A change in operating frequency or amplitude (if vibratory rollers are in use)
  - A defective roller drum
  - The use of an improper type of compaction equipment
  - A change in soil type



Soils and Aggregate Technician Certification

## Too Wet

- Soils that are too wet when compacted are susceptible to shearing and strength loss
- Corrective action for a soil compacted too wet is to:
  - Scarify
  - Aerate
  - Retest the moisture content
  - Recomact, if moisture content is within the specified range
  - Retest for both moisture and density



Soils and Aggregate Technician Certification

## Too Dry

- Soils that are too dry when compacted do not achieve the specified degree of densification as do properly moistened soils
- Corrective action for a soil compacted too dry is to:
  - Scarify
  - Add water
  - Mix thoroughly
  - Retest the moisture content
  - Recompect, if moisture content is within the specified range
  - Retest for both moisture and density

## Pipes in Fill Sections

- Where pipes must be placed in fill sections, it is not necessary that the entire embankment be constructed before cutting the trench but the embankment must be built up in the immediate vicinity of the pipe

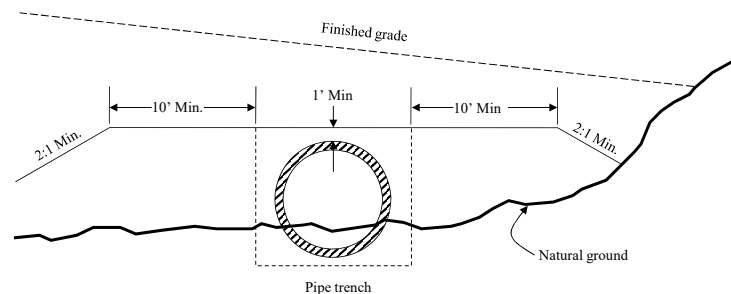

## Class A Culvert Bedding

- The bedding consists of a continuous concrete cradle for the pipe

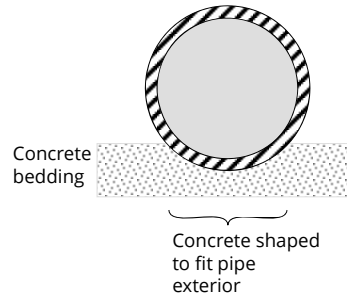

and Aggregate Technician Certification

## Class B Culvert Bedding

- The embankment is built up to at least one foot above the top of the proposed pipe before digging the trench
- The trench is then excavated to a depth which will allow the placement of six inches of bedding material below the pipe
- Additional bedding material is added so that it can be shaped by a template to fit the lower part of the pipe exterior for at least 10 percent of its overall height

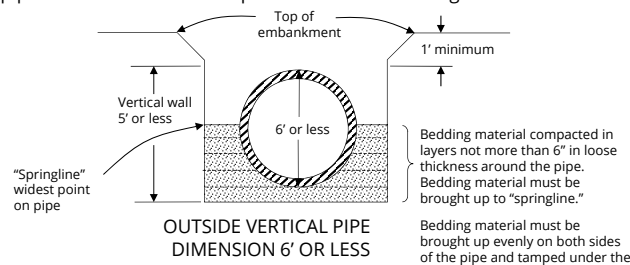

and Aggregate Technician Certification

## Class B Culvert Bedding

- Safety points:
  - Vertical walls must never exceed 5 feet
  - Where trenches must be deeper than 5 feet, the safety treatment depends on the outside vertical dimension of the pipe; the safety measures include sloping, benching, or both

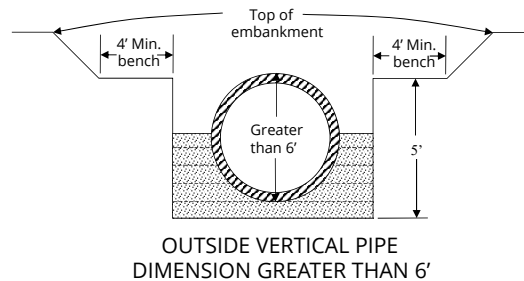

and Aggregate Technician Certification

## Class C Culvert Bedding

- The pipe is bedded in a shallow trench cut in the natural ground or the compacted embankment
- The trench must be cut to a depth not less than 10% of the outside vertical pipe dimension and shaped to fit the lower pipe exterior

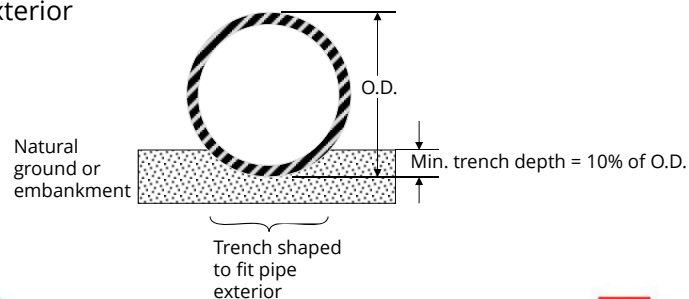

and Aggregate Technician Certification

## Backfill Requirements

- After the pipe is properly bedded, backfill material must be placed in 6-inch loose layers and each layer compacted as the backfill is brought up to the top of the trench
- Each layer must be mechanically tamped to 100 percent of maximum density and the backfill material must be within the moisture range at which this density can be obtained

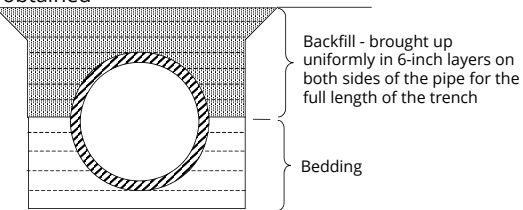

- Backfill material must consist of bedding material or fine, compactible soil selected from excavation or borrow as indicated on the plans



# 9

## **Quality Acceptance Testing**

# Quality Acceptance Testing

## References

SOP 7-1 (Nuclear Density Testing)



# Quality Acceptance Testing

- Generally, a quality-acceptance plan consists of breaking the total job down into lots
- A lot is accepted or rejected depending on the test results obtained through random sampling that represent the lot
- By handling the acceptance procedure in this way, the project engineer is able to determine the quality of the job on a lot-by-lot basis
- This benefits the construction unit and project engineer by identifying the lots that will be accepted and the lots that will be rejected
- As this type of information is accumulated from lot to lot, a better picture of the quality of the entire project is obtained



## Quality Acceptance Testing: Best Practices

- Use a “test strip” to determine the approximate number of passes needed to attain proper densities
- Test every lift as soon as compaction is completed
- Test every roller lane
- Test obvious weak spots
- Test roads and runways every 250 linear feet, staggering tests about the centerline
- Test parking lots and storage areas every 250 square yards
- Test trenches every 50 linear feet
- Remove all oversized materials
- Remove any pockets of organic or unsuitable soil material
- Increase the distance between tests as construction progresses, if initial checks are satisfactory



and Aggregate Technician Certification

## Quality Acceptance Testing: Procedure

- Identify Density/Moisture Requirements
  - Based on type of material being placed
  - Target values are determined by Materials and Tests and submitted to Project Supervisor.
- Determine Required Lot Size/Number of Tests
- Determine Test Locations
- Perform Test(s)
- Report Results



and Aggregate Technician Certification



## Identify Density/Moisture Requirements

- Acceptance criteria are different for Embankment, Aggregate Base, Etc. (as discussed in the last presentation)
- This information can be found in the corresponding section in the TDOT specs.
- The target values are determined by TDOT Materials and Tests personnel and will be made available by the TDOT Project Supervisor. \*These values may change during the course of the project, so be sure to make sure you have the most current numbers.



and Aggregate Technician Certification

## Determine Required: Lot Size/Number of Tests/Test Locations

- S.O.P. 1-1: Sampling and Testing Guide
  - Describes the testing frequency for all materials
  - Lists the person responsible for either obtaining the sample or performing the test.
  - Available in PDF format at:

<http://www.tdot.state.tn.us/materials/fieldops/sop/default.htm>

(see example in Part Five of S.O.P. 1-1)



and Aggregate Technician Certification

## TDOT Sampling Procedure (base stone example)

- SOP 1-1
  - 5 moisture/density tests are required for every 10,000-square-yard (SY) lot of material installed.
  - Tests are to be performed immediately before placing pavement structure
  - Specific test/sample locations are to be determined RANDOMLY



## Random Sampling

- Any portion of the population has equal chance of being selected
- Bias is introduced when judgment is used
- Use random number tables



## Why must we divide lots into sublots?

The diagram illustrates two sampling methods for a LOT (Lot). The top method, 'Random Sampling', shows a single grey rectangular area representing the LOT with four black dots scattered randomly. A horizontal bracket above it is labeled 'LOT'. The bottom method, 'Stratified Random Sampling', shows the same grey rectangular area divided into five equal-width vertical sections by red dashed lines. Each section contains one black dot. A horizontal bracket above the rightmost section is labeled 'SUBLOT' with an arrow pointing to it. The text 'and Aggregate Technician Certification' is partially visible at the bottom left of the diagram area.

Random Sampling

Stratified Random Sampling

LOT

SUBLOT

TN TDOT  
Department of  
Transportation

## TDOT Sampling Procedure (base stone example)

- 5 tests per LOT with each LOT divided into 5 sublots (1 test per sublot)
- The location longitudinally shall be taken randomly (using a number table)
- The lateral location should also be determined by a random number.

TN TDOT  
Department of  
Transportation

and Aggregate Technician Certification

## Random Number Table (example)

.20	.68	.98	.30	.27	.84	.54	.31	.05	.88
.61	.17	.38	.62	.55	.59	.67	.73	.43	.23
.27	.38	.84	.99	.72	.51	.48	.81	.77	.76
.24	.38	.40	.34	.76	.87	.60	.75	.49	.56
.88	.52	.25	.51	.79	.41	.33	.08	.32	.47
.62	.36	.97	.61	.28	.50	.81	.29	.75	.82
.94	.83	.35	.66	.42	.70	.44	.30	.54	.45



and Aggregate Technician Certification

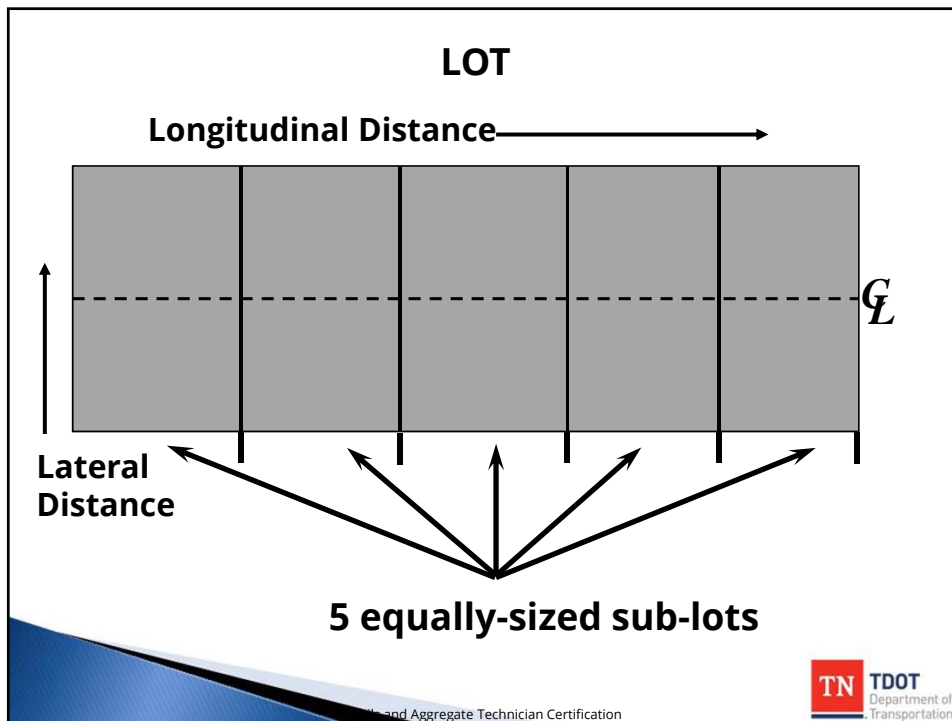

and Aggregate Technician Certification

## Testing Locations

- STEP 1-
  - Determine LOT size, and with known lane width, determine LOT and sub-lot lengths
- STEP 2-
  - With known beginning station, determine beginning sub-lot stations
- STEP 3-
  - Using random number table, or calculator, select 5 numbers

and Aggregate Technician Certification



## Testing Locations

- STEP 4-
  - Multiply random number by Sub- Lot Length, and add to beginning Sub-lot stations to determine longitudinal testing locations
- STEP 5-
  - Multiply random number by either lane or cross-sectional width to determine lateral testing location within each subplot

and Aggregate Technician Certification



## Example Problem

### Situation

- Placing Type A Base Material
- Typical base stone cross-section is 30 Feet
- Beginning Station 100+00



## A Bit About Station Numbers

- One "station" is equal to 100 linear feet.
- Locations between stations are described as a station number "+ XX" in additional feet.
- For example: If station "1 + 00" is the number that describes the first 100 feet of the project, then station "1 + 25" would be 25 feet past the first station.
- How many feet into the project would station number 100 + 00 be?



## A Bit More About Station Numbers

- To get from one station to another, simply drop the "+", add/subtract the numbers, and put the "+" back in the same place.
- Example: What would the final station be if we began at station number 100 + 00, and went forward 750 feet?

$$\begin{array}{r}
 100 + 00 \rightarrow 10000 \\
 + 750 \\
 \hline
 10750 \longrightarrow 107 + 50
 \end{array}$$



and Aggregate Technician Certification

## Example Problem (Continued)

- STEP 1- (Per SOP 1-1)
  - 10,000 SY LOT
  - LOT Length:  $10,000 \text{ yd}^2 \times 9 = 90,000 \text{ ft}^2$   
 $90,000 \text{ ft}^2 / 30 \text{ ft} = \underline{\underline{3000 \text{ ft length}}}$
  - SUB-LOT Length:  $3000 \text{ ft} / 5 = \underline{\underline{600 \text{ ft}}}$



and Aggregate Technician Certification

## Example Problem (Continued)

- STEP 2- (Beginning Station 100+00)

- 100+00                                 +600= 106+00
- 106+00                                 +600=112+00
- 112+00                                 +600=118+00
- 118+00                                 +600=124+00
- 124+00                                 +600=130+00

and Aggregate Technician Certification



LOT Length = 3000 feet

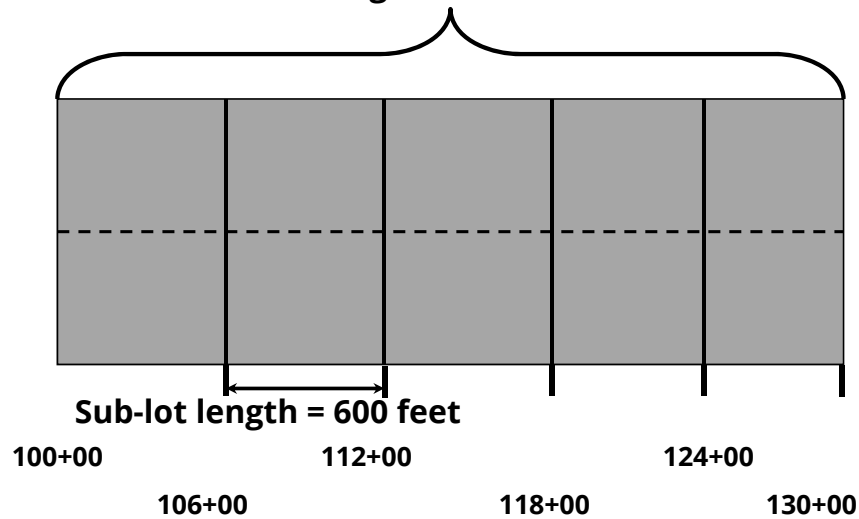

Sub-lot stations

and Aggregate Technician Certification







## Example Problem (Continued)

- STEP 3-
  - Using a random number table, select 5 numbers



and Aggregate Technician Certification

## Random Number Table

.20	.68	.98	.30	.27	.84	.54	.31	.05	.88
.61	.17	.38	.62		.59	.67	.73		.23
.27	.38	.84	.99	.72	.51	.48	.81	.77	.76
	.38	.40	.34	.76	.87	.60	.75	.49	.56
.88	.52	.25	.51	.79		.33	.08	.32	.47
.62	.36	.97	.61	.28	.50	.81	.29	.75	.82
.94	.83	.35	.66	.42	.70	.44		.54	.45



and Aggregate Technician Certification

## Example Problem (Continued)

- Step 4 -
- Use
  - Sub-lot Length from Step 1
  - Sub-lot Stations from Step 2
  - Random Numbers from Step 3



and Aggregate Technician Certification

## Example Problem (Continued)

- STEP 4 -
  - $0.41 \times 600' = 246'$ 
    - $2+46 + 100+00 = \underline{102+46}$
  - $0.30 \times 600' = 180'$ 
    - $1+80 + 106+00 = \underline{107+80}$
  - $0.43 \times 600' = 258'$ 
    - $2+58 + 112+00 = \underline{114+58}$
  - $0.55 \times 600' = 330'$ 
    - $3+30 + 118+00 = \underline{121+30}$
  - $0.24 \times 600' = 144'$ 
    - $1+44 + 124+00 = \underline{125+44}$



and Aggregate Technician Certification

## Example Problem (Continued)

- STEP 5-
  - Randomly select the transverse location for testing



and Aggregate Technician Certification

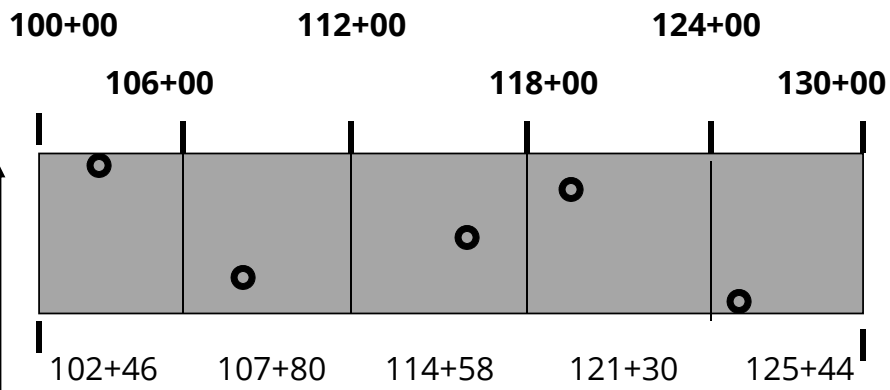

**Lateral Distance is determined by multiplying random numbers by road width.**



and Aggregate Technician Certification

## Nuclear Density/Moisture Testing

- You must have attended a Radiation Safety course prior to using a Nuclear Gauge!

[\(click for example\)](#)

- TDOT references AASHTO T-310 as the standard test method.
- **SAFETY FIRST!!!!**



and Aggregate Technician Certification

## Nuclear Density/Moisture Testing

- Never handle a nuclear gauge without wearing your own personal radiation dosimeter.
- Never leave a nuclear gauge unattended on a job site.



and Aggregate Technician Certification

## Nuclear Density/Moisture Testing

- Regardless of gauge manufacturer (Troloxer, Humbolt, Instrotek, etc.), all gauges utilize the same basic components.
- All tests performed on soil and aggregate will be using the *Direct Transmission* method.

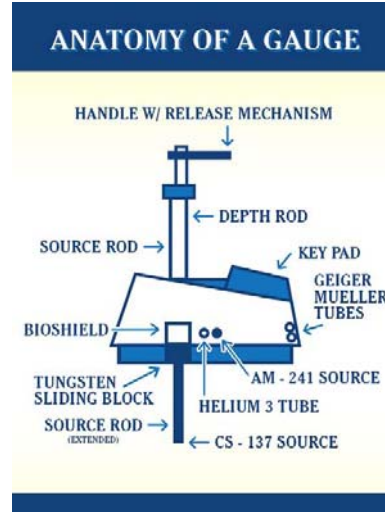

and Aggregate Technician Certification

## Nuclear Density/Moisture Testing



and Aggregate Technician Certification

## Nuclear Density/Moisture Testing

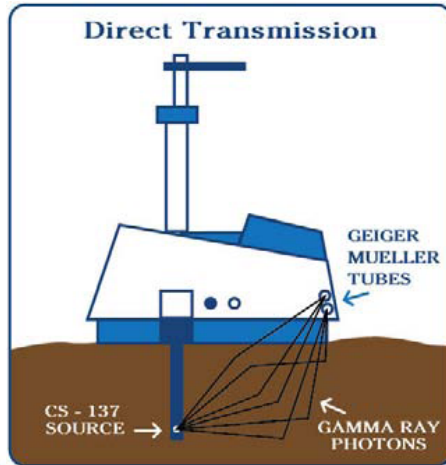

- When taking a test the gauge measures the amount of radiation detected over a predetermined timeframe, such as one minute.
- The detector tubes count the radiation that is able to pass through the material between the bottom of the source rod and the detector tubes.
- The denser the material, the lower the amount of radiation that is able to reach the detector tubes to be counted.



and Aggregate Technician Certification

## Standard Counts

- Standard counts measure the number of counts received from the density and moisture sources and provide a quick reference check to ensure that the gauge is operating correctly.
- A standard count should be taken daily and the results should be very close to previous standard counts, typically 1% for density and 2% for moisture.



and Aggregate Technician Certification

## Standard Counts (Continued)



- If the last count has been longer than 60 days a new standard count average may need to be established. This can be done by taking three more tests and averaging these most recent results to establish a new count.
- If the gauge still does not match it's standard count values, it must ***not*** be used.
- Check the gauge manual and AASHTO T-310 for additional information.



and Aggregate Technician Certification

## Nuclear Density/Moisture Testing

Enter the predetermined proctor density and moisture content for the material you will be testing. This will enable the gauge to calculate the dry density and determine the percent compaction.

*Where does this information come from?*



and Aggregate Technician Certification



## Nuclear Density/Moisture Testing



When testing on soils always prepare the ground by using the scraper plate to smooth out any obstacles or fill in any voids.

This will reduce the chance that open pockets or protruding objects impact the reading.



and Aggregate Technician Certification

## Nuclear Density/Moisture Testing

When using the drill rod to make a hole in the compacted material for testing, always make sure to first place the drill rod removal device – this is a mistake that will probably be made only once.



and Aggregate Technician Certification



## Nuclear Density/Moisture Testing



- Etch around the base of the scraper plate before picking it up, then place the gauge down inside of this etched area.



- The opening for the source rod will be positioned over the hole that was drilled.

and Aggregate Technician Certification



## Nuclear Density/Moisture Testing

- Pull or depress the gauge trigger and drop the rod into the hole.
- Before taking a test push the gauge towards the side of the hole with the detector tubes. This ensures that there is no air gap between the source rod and the side of the hole.
- Make sure that the source rod is well seated in the depth position notch. Any misalignment will impact the results.



and Aggregate Technician Certification



## Nuclear Density/Moisture Testing



**IMPORTANT:** Do not extend the source rod to guide it into the hole! This exposes you and others to an unnecessary exposure of radiation.



and Aggregate Technician Certification

## Nuclear Density/Moisture Testing

- Secure and record one or more 1-minute readings.
- The gauge may be rotated about the axis of the probe to obtain additional readings.
- Do not stand right next to the gauge while running a test.
- Never run a test within 30 ft of another gauge.



and Aggregate Technician Certification

# Nuclear Density/Moisture Testing

- Report test results on TDOT Form no. DT-0314
- All forms are available at:

<http://www.tn.gov/tdot/article/transp-ortation-materials-tests-division-field-operations-forms>

*How do we know if the results are acceptable?  
If they're not, what should we do?*

STATE OF TENNESSEE  
DEPARTMENT OF TRANSPORTATION  
DIVISION OF MATERIALS AND TESTS  
4401 CENTENNIAL BLVD.  
NASHVILLE, TENNESSEE 37203-4368

**SAMPL**

Project Reference No. 02 County Anderson Date 01/26/17  
Project No. 1000000000 Nuclear gauge no. 001 Contract No. 0000 Region 2

Lot No.	1				
Test No.	1	2	3	4	5
Station	456.77	28.50	456.77	28.50	456.77
Offset (ft.)	0.00	2.00	0.00	2.00	0.00
Feet Below Grade	0	0	0	0	0
Moisture Standard Count	807	807	807	807	807
Moisture Count Rate	---	---	---	---	---
Probe Depth	0"	0"	0"	0"	0"
Density Standard Count	2769	2769	2769	2769	2769
Density Count	2460	2387	2762	2961	2460
Density Count Rate	---	---	---	---	---
Unit Weight Wet (pcf)	121.0	121.1	121.4	121.4	121.7
Moisture (pcf)	23.7	23.8	23.7	23.8	24.2
Unit Weight Dry (pcf)	97.3	97.3	97.7	97.6	97.5
Percent Moisture	24.4	24.4	24.3	24.3	24.7
Cut Station	456.80	456.80	456.80	456.80	456.80
Sample Number	00	00	00	00	00
Proctor Density	96.2	96.2	96.2	96.2	96.2
Optimum Moisture	22.3	22.3	22.3	22.3	22.3
Percent +4	26.3	26.3	26.3	26.3	26.3
Corrected Proctor Density					
Corrected Optimum Moisture					
Percent Compaction	93.2	94.1	97.9	95.6	96.7



# Nuclear Gauge Contacts

## Headquarters Radiation Safety Officer (RSO):

Jimmy Britt (615) 350-4164  
Rocky Kelley (321) 482-3071

## Regional RSOs

Region 1: Billy Goins (865) 806-1935  
Region 2: Jeff Yarworth (423) 510-1159  
Region 3: Mark Hand (615) 389-5217  
Region 4: Marc Turner (731) 234-6048



## Nuclear Density/Moisture Testing



- Always return the gauge to its case after use.
- Make sure the case is secured properly before transporting to another test location.
- Do not store the gauge in your basement.



and Aggregate Technician Certification



# 10

**TDOT Forms**





**STATE OF TENNESSEE**  
**DEPARTMENT OF TRANSPORTATION**  
**DIVISION OF MATERIALS AND TESTS**  
 6601 CENTENNIAL BLVD.  
 NASHVILLE, TENNESSEE 37243-0360

DENSITY WORKSHEET - NUCLEAR METHOD

Project Reference No. \_\_\_\_\_ Date \_\_\_\_\_  
 Project No. \_\_\_\_\_ County \_\_\_\_\_ Region \_\_\_\_\_  
 Nuclear gauge no. \_\_\_\_\_ Contract No. \_\_\_\_\_

Lot No.					
Test No.					
Station					
Offset (ft.)					
Feet Below Grade					
Moisture Standard Count					
Moisture Count					
Moisture Count Ratio					
Probe Depth					
Density Standard Count					
Density Count					
Density Count Ratio					
Unit Weight Wet (pcf)					
Moisture (pcf)					
Unit Weight Dry (pcf)					
Percent Moisture					
Cut Station					
Sample Number					
Proctor Density (pcf)					
Optimum Moisture, %					
Dry Weight of +4 Material					
Dry Weight of Total Material					
Percent +4 Material					
Sp. Gravity of +4 Material					
Corrected Proctor Density					
Corrected Optimum Moisture					
Percent Compaction					

Original to:  
 Headquarters Materials and Tests  
 Copies to:  
 Regional Materials and Tests  
 Project Supervisor



**STATE OF TENNESSEE  
 DEPARTMENT OF TRANSPORTATION  
 DIVISION OF MATERIALS AND TESTS  
 6601 CENTENNIAL BLVD.  
 NASHVILLE, TENNESSEE 37243-0360**

**PROCTOR DENSITY REPORT**

Project Reference No. \_\_\_\_\_ County \_\_\_\_\_ Region \_\_\_\_\_  
 Project No. \_\_\_\_\_ Contract No. \_\_\_\_\_  
 Material \_\_\_\_\_ Project Supervisor \_\_\_\_\_  
 Report No. \_\_\_\_\_ Date Sampled \_\_\_\_\_  
 Serial No. \_\_\_\_\_ Date Reported \_\_\_\_\_  
 Contractor \_\_\_\_\_ Sampled By \_\_\_\_\_  
 Producer \_\_\_\_\_ Sampled From \_\_\_\_\_

**GRADATION - TOTAL PERCENT PASSING**

Sample No.					
Station					
Depth, ft.					
Location, ft.					
2"					
1-1/2"					
1"					
3/4"					
3/8"					
No. 4					
No. 10					
No. 16					
No. 40					
No. 100					
No. 200					
Silt and Clay					
Clay					

**SOIL CONSTANTS**

Liquid Limit					
Plastic Limit					
Plasticity Index					
Calculated PI					
Type					
Group					

**DENSITY CORRECTED FOR +4 MATERIAL**

Proctor Density					
Optimum Moisture					
95 % Density					
Moisture Range Above Subgrade					
Moisture Range Below Subgrade					

\_\_\_\_\_  
 Regional Materials and Tests

Approved for Information Only

\_\_\_\_\_  
 Engineer of Materials and Tests

# 11

**Standard Operating  
Procedure 1-1, Part 2  
(SOP 1-1)**



**PART TWO: ACCEPTANCE SAMPLES AND TESTS**

Type of Construction	Material	Test	Sampled By	Frequency	Location or Time of Sampling	Remarks
Portland Cement Concrete (Except Prestressed, Precast, Pavement and Base)	Cement, Fly Ash, and GGBFS	Acceptance from Qualified Products List (Verification Sampling Required)				Must be from approved source; if not, must have complete lab tests before being used on project.
	Curing Compound	Acceptance from Qualified Products List (Verification Sampling Required)				A compatible Type 1-D, Class B membrane shall be used when texture coating is specified.
	Chemical Admixtures	Acceptance from Qualified Products List				Admixture must be on approved list and have the brand shown on concrete design. Check dosage amounts for compliance with concrete design.
	Aggregate: Coarse and Fine	Acceptance from Producer's Supplier's List (Verification Sampling Required)				Must be approved material.
	Reinforcing Steel (Bars)	Acceptance by Certification (Verification Sampling Required)				See attached Verification Check Samples and Tests section.
	Completed Concrete Mix	Cylinders (28-day) Slump, Air Content, <b>Mix Temperature</b>  *All early break cylinders shall conform to the requirements as stated in Part 1 of the SOP Guide.	Project Inspector	*A complete set of tests and <b>pair</b> of cylinders for each 100 yd <sup>3</sup> placed per critical unit of structure. For Class D or L, One complete set of tests for each of the first three loads. One <b>pair</b> of cylinders shall be cast from one of the first three passing loads; additional tests and <b>pairs</b> of cylinders to be made for each additional 50 yd <sup>3</sup>	Randomly selected during placement	Determine Slump and Air Content from the same sample of concrete that cylinders are made from. For Class D or L, Bridge Deck Concrete per SOP 4-1; concrete placed by pumping shall be checked for air content at the discharge end of the truck chute immediately prior to pumping. <b>*Complete set of tests shall be performed on the initial load for quality control/informational purposes, not for acceptance.</b> The volumes of noncritical items may be combined when utilizing the same ready mix plant.
Portland Cement Concrete Non-Critical Structures for <b>Small Quantities (Not to exceed 25 yd<sup>3</sup> per week per project for combined concrete items.)</b>	Cement and Fly Ash GGBFS	Acceptance from Qualified Products List (Verification sampling required)				Must be from approved source; if not, must have complete lab tests before being used on project.
	Curing Compound	Acceptance from Qualified Products List (Verification sampling required)				A compatible Type 1-D, Class B membrane shall be used when texture coating is specified.
	Chemical Admixtures	Acceptance from Qualified Products List				Admixture must be on approved list and have the brand shown on concrete design. Check dosage amounts for compliance with concrete design.
	Aggregate: Coarse and Fine	Acceptance from Producer's Supplier's List (Verification Sampling Required)				Must be approved material.
	Reinforcing Steel (Bars)	Acceptance by Certification (Verification Sampling Required)				
	Completed Concrete Mix	Visual Inspection, Cylinders, (28 day) Slump, Air Content, <b>Mix Temperature</b>  *All early break cylinders shall conform to the requirements as stated in Part 1 of the SOP Guide.	Project Inspector	*Complete set of tests and <b>pair</b> of cylinders for pours of 25 yd <sup>3</sup> or less weekly. If over 25 yd <sup>3</sup> per week <b>is</b> poured then follow procedures outlined in Portland Cement Concrete (Except Prestressed, Precast, Pavement and Base). Delivery tickets must accompany each load & contain batch weights, class of concrete & time of batching.	Randomly selected at placement site	NOT TO BE USED IN MAJOR STRUCTURES OR STRUCTURALLY CRITICAL ITEMS.  ONLY FOR: Sidewalks, Curbs & Gutter, Building Foundations, Slope Paving, Ditch Paving, Guardrail Anchorage, Small Culvert Headwalls (30" or less), Fence Posts, Catch Basins, Manhole Bases & Inlets, and Small Sign Bases. <b>*Complete set of tests shall be performed on the initial load for quality control/informational purposes, not for acceptance.</b>
Pre-approved Pre-packaged Concrete Mixtures	Acceptance from Qualified Products List				To be limited to 2 yd <sup>3</sup> per day for items as listed above.	

**PART TWO: ACCEPTANCE SAMPLES AND TESTS**

Type of Construction	Material	Test	Sampled By	Frequency	Location or Time of Sampling	Remarks
Portland Cement Concrete - Pavement & Base	Cement, Fly Ash, and GGBFS	Acceptance from Qualified Products List (Verification sampling required)				Must be from approved source. If not, must have complete lab analysis and approved before being used.
	Curing Compound	Acceptance from Qualified Products List (Verification sampling required)				A compatible Type 1-D, Class B membrane shall be used when texture coating is specified.
	Chemical Admixtures	Acceptance from Qualified Products List				Admixture must be on approved list and have the brand shown on concrete design. Check dosage amounts for compliance with concrete design.
	Aggregate: Coarse and Fine	Acceptance from Producer's Supplier's List (Verification Sampling Required)				Must be approved material.
	Completed Concrete Mix	Compressive Strength (Cylinders) Slump, Air Content, Mix Temperature	Project Inspector	*One pair each 400 yd <sup>3</sup> . In areas where class A is allowed, the frequency shall be the same as Portland Cement Concrete.	Placement site	Additional test specimens will be required if pavement is to be opened to traffic within 14 days after placement. Determine Slump and Air Content from same sample of mix used for cylinders. Make additional Slump and Air Content determinations as required for control. Class CP concrete use 6x12 cylinders. <b>*Complete set of tests shall be performed on the initial load for quality control/informational purposes, not for acceptance.</b>
		Depth Measurement	Contractor Monitored by Project Inspector	One core per 1,000 linear feet of poured width, with a minimum of 1 core for each interchange ramp	Completed pavement	When thickness of core from a unit is deficient more than 1/4" and not more than 1" from Plan thickness, take 2 additional cores at intervals of not less than 300' within the unit. Use the average of the three cores to determine thickness.
	Dowel and Tie Bars	Acceptance by Certification (Verification sampling required)				Assembly to be approved by the Engineer.
	Sealant	Acceptance by Qualified Products List				
Prestressed Concrete	Cement, Fly Ash, and GGBFS	Acceptance from Qualified Products List (Verification sampling required)				Must be from approved source; if not, must have complete lab tests before being used on project.
	Curing Compound	Acceptance from Qualified Products List (Verification sampling required)				
	Chemical Admixtures	Acceptance by Qualified Products List				Admixture must be on approved list and have the brand shown on concrete design. Check dosage amounts for compliance with concrete design.
	Aggregate: Coarse and Fine	Acceptance from Producer's Supplier's List (Verification Sampling Required)				Must be approved material.
	Reinforcing Steel (Bars)	Acceptance by Certified Mill Test Report (Verification Sampling Required)				
	Prestressing Strands	Acceptance by Certified Mill Test Report (Verification Sampling Required)				
	Finished Product	Visual Inspection	Materials & Tests	After casting and before shipment	Prestress producer's plant	Each item to be inspected for straightness, cracks, honeycomb, size and appearance. Cosmetic Patching shall be cured prior to shipment.
	Completed Concrete Mix	Slump, Air and Mix Temperatures	Materials & Tests or Contractor monitored by TDOT personnel.	1 set of tests per pair of cylinders	At the discretion of the Inspector or a minimum of one per pour.	Additional tests performed when apparent slump change is indicated or as directed.
Cylinders (Beams)		Materials & Tests or Contractor monitored by TDOT personnel.	At least 1 pair at the beginning, middle and end of the bed		1 pair for 28 day strength, 1 pair for back up	
Cylinders (Panels/Piling)		Materials & Tests or Contractor monitored by TDOT personnel.	One pair at beginning, and one pair at the end of the pour		1 pair for 28 day strength, 1 pair for back up	
Cylinders (Tension Release)		Materials & Tests or Contractor monitored by TDOT personnel.	One pair at beginning, and one pair at the end for tension release of the bed		Additional specimens may be necessary	

**PART TWO: ACCEPTANCE SAMPLES AND TESTS**

Type of Construction	Material	Test	Sampled By	Frequency	Location or Time of Sampling	Remarks
Precast concrete noise wall panels, retaining wall panels, and precast drainage structures including pipes, headwalls, manholes, catch basins, box culverts, and structural spans	Finished Product	Acceptance by Certification in accordance with SOP 5-3 (Verification sampling required)				Each shipment must be accompanied by a completed certification form. Each item shall be inspected after delivery to the project for cracks, spalls and/or appearance by project personnel prior to incorporating product into the work.
Precast Concrete Abutment Blocks and Approach Slabs	Finished Product	Slump, Temperature, and Air	Materials & Tests or Contractor monitored by TDOT personnel	Minimum 1 set of test per pour	Precast producer plant	
		Cylinders	Materials & Tests or Contractor monitored by TDOT personnel	One set at beginning, and 1 set at the end of the pour	Precast producer plant	
Earth Retaining Structures	Backfill	Density	Project inspector	1 per every 500 tons or fraction thereof	Project site	
		Acceptance from Producer's Supplier's List (Verification Sampling Required)				Must be approved material.
	Select Granular Backfill	Quality pH Internal angle of friction	Materials & Tests	1 @ beginning of Project and then every 6 months	Aggregate plant	
		Density	Project inspector	1 per every 500 tons	Project site	
		Eletro-Chemical Analysis	Producer	1 per Source @ Beg of Project & every 2 years thereafter	Aggregate plant	Additional Test required w/ appearance change
		Gradation	Materials & Tests	Beginning of project	Aggregate plant or Roadway	
	Project Inspector		One test every 1000 tons (Min. 1 per week)	Aggregate plant or Roadway		
Finished Product	Precast concrete Products	Acceptance in accordance w/SOP 5-3 and Special Provision 624 Retaining Walls (Verification testing required)				
	Modular block	Acceptance in accordance w/Special Provision 624 Retaining Walls (Verification testing required)				Verification required before use
Prime, Tack and Sealer	Emulsions	Acceptance by Certification in accordance with SOP 3-2 (Verification Sampling Required)				Each shipment must be accompanied by TDOT form DT-0293E materials certification report.
Prime Tack and Sealers (Small Quantities)	Emulsions	Visually inspect for contamination	Project Inspector	1 per project	Project Site	Not to exceed 3 tons tack and 3 tons prime per project. Supplier to furnish certification (may be non-project specific) and delivery tickets showing quantities.
Bituminous Plant Mix Pavements	Aggregate	Acceptance from Producer's Supplier's List (Verification Sampling Required)				Must be approved material.
		Fractured Face Count, Glassy particles by weight	Project Inspector	Min. of 1 per project	Coarse aggregate Stockpile	Plus #4 (4.75mm) Material
	Performance-Graded Asphalt Cement	Acceptance by Certification in accordance with SOP 3-1 (Verification Required in accordance with Part Three herein)			Governed by process See SOP 3-1	Each shipment must be accompanied by TDOT form DT-0293PG materials certification report.
	All Plant Mix Asphalt	Mix temperature	On Roadway by Project Insp.	Every fifth load.	From truck prior to leaving plant and on roadway prior to deposit into paver or transfer device.	Temperatures to be recorded on the delivery ticket. Tests at the plant by producer at the discretion of Materials & Tests Supervisor.
		Stripping-10 min. boil test	Project Inspector	Once daily	Truck and Asphalt Plant	Plus #4 (4.75mm) Material on selected visually from mix sample.
Plant Mix Asphalt Gradings A, B, BM, BM2, C, CW, D, E, and E Shoulder	Density	Project Inspector	1,000 tons	As soon as practical after compaction, when nuclear method is used. When used, cores will be obtained in accordance with SP407DEN.	Each lot shall be divided into 5 equal-sized sublots, and one test should be performed per each sublot. Longitudinal test locations should be determined randomly. <b>Transverse locations are determined randomly with one test 1' off each edge, one test in each wheel path, and one test in the center of the lane.</b>	

**PART TWO: ACCEPTANCE SAMPLES AND TESTS**

Type of Construction	Material	Test	Sampled By	Frequency	Location or Time of Sampling	Remarks
Bituminous Plant Mix Pavements	Plant Mix Asphalt Grading B, BM, BM2, C, CW, D, E, CS, TLD, & TL	Asphalt Content AASHTO T-164, Method E-II by extraction, or AASHTO T-308 by ignition oven	Project Inspector	1 test for every 1000 tons randomly	Completed mix in truck or on roadway	AASHTO T-164 Method E-II will be performed by pouring the extracted asphalt and solvent through nested No. 16 and No. 200 mesh sieves. AASHTO T 164 Method A may be used for modified asphalt or when problems are encountered filtering according to Method E-II. May not be required on production days of less than 100 tons. Ignition oven may be utilized to determine AC content and gradation.
		Aggregate Gradation AASHTO T-30 and AASHTO T-11				
		Air Voids & Volumetric Properties (T166, T209, T269)	Project Inspector or Materials and Tests	During Test Strip Construction or Mix Verification	Completed mix in truck or on roadway	Applies only to mixes requiring a design. Verification Sample required to be submitted to Regional Lab.
	LOI (Surface Mix only)	Project Inspector	One sample per day for Surface Mix only	Completed mix in truck	If daily sample fails, take 3 cores per lot placed that day to determine LOI. Penalty for failure to meet.	
	Plant Mix Asphalt Grading A, A-S, A-CRL, & Asphalt Treated Permeable Base	Aggregate Gradation AASHTO T-30 and AASHTO T-11	Project Inspector	1 test for every 1000 tons randomly	Completed mix in truck or on roadway	AASHTO T-164 Method E-II will be performed by pouring the extracted asphalt and solvent through nested No. 16 and No. 200 mesh sieves. AASHTO T 164 Method A may be used for modified asphalt or when problems are encountered filtering according to Method E-II. May not be required on production days of less than 100 tons. Ignition oven may be utilized to determine gradation.
Bituminous Plant Mix Pavements for <u>Small Quantities</u>	Bituminous Mixture	Visual Inspection	Project Inspector	Occasionally. Delivery ticket must accompany each load & contain weight of mix.	Placement site	Not to exceed 1000 tons of each type mix per project. Supplier to furnish certification showing type of mix and compliance with TDOT specifications. TDOT reserves right to perform any testing deemed necessary. Mix shall be formulated from a previously approved Job Mix Formula.
Bituminous Surface: Surface Treatment, Microsurfacing, Slurry Sealing, and related similar processes	Aggregate	Gradation & Washing	Project Inspector or Materials & Tests	One each 500 tons for each size aggregate.	At source or at project prior to incorporating into work.	Inspection required before material use.
		Fractured face count	Project Inspector or Materials & Tests	Minimum of 1 per project	At project prior to incorporating into work	Plus No. 4 (4.75mm) sieve material, gravel mixes only.
		Loss on Ignition (LOI)	Project Inspector or Materials & Tests	Minimum of 1 per week	From stockpiled materials. If blended aggregate, then after blending.	Accept/deduct in accordance with 407.20.C.3, pgf 6
		Glassy particles by weight	Project Inspector or Materials & Tests	Minimum of 1 per project	At project prior to incorporating into work	Plus No. 4 (4.75mm) sieve material, slag mixes only.
		Acceptance from Producer's Supplier's List (Verification Sampling Required)				
	Emulsions	Acceptance by Certification in accordance with SOP 3-2. (Verification Sampling Required)				Each shipment must be accompanied by a notarized materials certification report. DT0293E See attached Verification/Check Samples & Tests section.
Treated Permeable Base	Asphalt Treated Permeable Base or Portland Cement Treated Permeable Base	Thickness	Contractor to obtain specimen at locations identified by Project Inspector	One core per unit or fraction of unit. A unit is equal to a paver mat width 1,000 ft in length.	Prior to being overlaid	When thickness of core from a unit is deficient more than 1/4" and not more than 1" from Plan thickness, take 2 additional cores at intervals of not less than 300' within the unit. Use the averaged of the three cores to determine thickness.

**PART TWO: ACCEPTANCE SAMPLES AND TESTS**

Type of Construction	Material	Test	Sampled By	Frequency	Location or Time of Sampling	Remarks
Embankment	Soil	Proctor Density & Optimum Moisture	Materials & Tests	As required by material changes	Cuts sampled prior to construction. Borrow pits sampled as required prior to placement.	
		Density, Moisture	Project Inspector	One test each 10" of lift not to exceed 1500 ft roadway or 5000 yd <sup>3</sup> . Exception: Within 50 ft of a bridge end (deck or box) 1 test will be performed for each lift. The test will be performed alternately on the embankment and on the backfill material.	All tests will be performed at random locations. During construction, immediately after compaction.	Density tests will not be required for embankment containing more than 50% of plus 3/4" sieve material.  See Standard Specs. 205 for correct formation of embankment.
Subgrade Preparation	Soil	Proctor Density & Optimum Moisture	Materials & Tests	As required by material changes.	May be sampled before grading construction or after grading prior to subgrade preparation.	
		Density, Moisture	Project Inspector	5 tests per 10,000 yd <sup>2</sup> lot for top 6 inches	Immediately before placing pavement structure	Average of 5 tests in lot used to determine pass-fail, with no individual test below 95% of Proctor. Average lot to be no less than 100%.
Subgrade Treatment: Lime	Soil-Lime Mixture	Proctor Density, Optimum Moisture	Project Inspector	Prior to beginning of construction	At beginning of compaction	Additional tests may be required to account for material changes.  Prior to beginning of construction, samples of soil & lime will be submitted to Central Lab for Proctor Density lab tests.
		Density, Moisture	Project Inspector	5 tests per 10,000 yd <sup>2</sup> lot	Immediately following compaction	Average of 5 tests in lot to determine pass - fail.
		Pulverization	Project Inspector	1 test per 10,000 yd <sup>2</sup>	At the beginning of compaction	Sieve test requirement See Standard Specs. 304.06
		Thickness	Project Inspector	5 tests per 10,000 yd <sup>2</sup>	Job site	
Soil-Cement Base	Cement	Acceptance by Certification (Verification Sampling Required)				Cement must be from an approved source or be approved prior to use.
	Water	Visual Inspection	Project Inspector	At the beginning of work	As source changes	
	Soil-Cement Mixture	Pulverization	Project Inspector	1 test per 10,000 yd <sup>2</sup>	After mixing, before compaction	See Standard Specs. 304.06
		Density, Moisture	Project Inspector	5 tests per 10,000 yd <sup>2</sup> lot	Immediately following compaction	Average of 5 tests in lot to determine pass - fail
		Thickness	Project Inspector	5 tests per 10,000 yd <sup>2</sup> lot	After final finish of base	

**PART TWO: ACCEPTANCE SAMPLES AND TESTS**

Type of Construction	Material	Test	Sampled By	Frequency	Location or Time of Sampling	Remarks	
Mineral Aggregate Base & Surface	Aggregate	Acceptance from Producer's Supplier's List (Verification Sampling Required)					Must be approved material.
		Proctor, Sp. Gravity, Optimum Moisture	Materials & Tests	Once per year for producers or as material changes	Sampled at source	Quality report required for each project	
		Gradation, Moisture	Project Inspector	Initial and each 2500 tons	Sampled from plant or roadway	A minimum of 1 sample per week for small quantities not to exceed 500 tons per week. Note: A minimum of 1 sample per week when aggregate is used for maintenance or incidental purposes. First sample should be taken at beginning of day.	
		Density, Moisture	Project Inspector	5 tests per 10,000 yd <sup>2</sup> lot	Immediately following Compaction	Average of 5 test in lot used to determine pass - fail. (Check sp. gravity not always required. See Standard Specs. 303.09	
		Thickness	Project Inspector or Survey Party	Five test holes per lot of approximately 10,000 yd <sup>2</sup> or profile check at each break point at 50 ft intervals	After base completed	On test holes - lot average considered one test	
	Calcium Chloride, Sodium Chloride	Quality	Project Inspector	One sample each shipment to project	Sample from stock before use		
Mineral Aggregate Base and Surface for Small Quantities	Mineral Aggregate	Visual Inspection	Project Inspector	As directed by Project Engineer	Project site	Not to exceed 500 tons per project. Must be from approved source.	
Aggregate for Underdrains	Mineral Aggregate	Gradation	Project inspector or Material and Tests representative	One test every 1000 tons (Min. 1 per week)	Project site or plant stockpile	Must be from an Approved Source	
Aggregate-Cement Base Courses	Cement	Acceptance by Certification (Verification Sampling Required)				Cement must be from approved source or to be accepted prior to use.	
	Aggregate	Gradation	Project Inspector	One each 2500 tons	Sampled from plant stockpile	In special cases, this test run by Materials & Tests.	
		Acceptance from Producer's Supplier's List (Verification Sampling Required)				Must be approved material.	
	Water	Quality	Project Inspector	At the beginning of construction and when source changes	Source prior to start of work	Water of potable quality may be used without testing.	
	Aggregate-Cement Mixture	Density, Moisture	Project Inspector	5 tests per lot of approx. 10,000 yd <sup>2</sup>	Immediately following compaction	Average of 5 tests in lot used to determine pass - fail. Not required for Cement Treated Permeable Base.	
		Thickness	Project Inspector or Survey Party	Five test holes per lot of approx. 10,000 yd <sup>2</sup> or profile check at each break point at 50 ft intervals	After base completed	On test holes - lot average considered one test	
Moisture		Project Inspector	1 each 2500 tons or 2 per day	At time of weighing	First sample should be taken at beginning of day.		

**PART TWO: ACCEPTANCE SAMPLES AND TESTS**

Type of Construction	Material	Test	Sampled By	Frequency	Location or Time of Sampling	Remarks
Aggregate - Lime Fly Ash Base Course	Hydrated Lime	Acceptance by Certification (Verification Sampling Required)				Must be from approved source or tested and approved prior to use.
	Fly Ash	Acceptance from Qualified Products List (Verification Sampling Required)				Must be from approved source or tested and approved prior to use.
	Aggregate	Gradation	Project Inspector	One each 2500 tons	Sampled from plant stockpile.	Must be from approved source. In special cases, this test is performed by Materials & Tests.
	Water	Quality	Project Inspector	At the beginning of construction and when source changes	Source prior to start of work	Water of potable quality may be used without testing.
	Aggregate-Lime-Fly Ash Mixture	Density, Moisture	Project Inspector	5 tests per lot of approximately 10,000 yd <sup>2</sup>	Immediately following compaction	Average of 5 tests in lot used to determine pass - fail. Not required for Cement Treated Permeable Base.
		Thickness	Project Inspector or Survey Party	Five test holes per lot of approximately 10,000 yd <sup>2</sup> or profile check at each break point at 50 ft intervals	After base completed	On test holes - lot average considered one test
Conditioning Mineral Aggregate Base	Aggregate	Optimum Moisture	Materials & Tests	1 per project and as materials change	Sampled from roadway prior to beginning the conditioning	
		Proctor	Materials & Tests	1 per year for producers or as material changes	Sampled from roadway prior to beginning the conditioning	
		Density, Moisture	Project Inspector	5 tests per 10,000yd <sup>2</sup> lot	Immediately following compaction	Average of 5 tests per lot used to determine pass - fail
	Calcium Chloride, Sodium Chloride	Chemical Analysis	Project Inspector	1 sample each shipment to project	Sampled from stock before use	Submit sample to Headquarters Lab for testing
Miscellaneous and Small Quantities For Non-Critical Items	Aggregate: For use other than in Portland Cement Concrete	Visually inspect for contamination	Project Inspector	Occasionally	Placement site	Must be from approved source. Not to exceed 100 tons per day nor more than 500 tons per project. For use in pipe bedding, underdrains, etc.
	Masonry Items including: Concrete Block, Brick, R/W Markers	Visual Inspection and Dimension Check	Project Inspector	Occasionally	Placement site	Supplier to furnish certification. Not to exceed: Concrete block - 100 Brick ----- 1,000 R/W markers --- 20
	Fence Fabric or Wire, Fence Posts & Braces, etc.	Visual Inspection and Dimension Check	Project Inspector	Occasionally	Placement site	Not to exceed 1000 lin. Ft. (300 m) per project. Supplier to furnish certification.
	P.V.C. Pipe and Underdrain Pipe 300 mm (12") D	Visual Inspection and Dimension Check	Project Inspector	Occasionally	Placement site	Not to exceed 500 lin. ft. per project. Supplier to furnish certification.
	Delineators & Posts	Acceptance from Qualified Products List (No Verification Sampling Required)				Not to exceed 100 pieces of each per project. Supplier to furnish certification.

**PART THREE: VERIFICATION/CHECK SAMPLES AND TESTS**

Type of Construction	Material	Test	Sampled By	Frequency	Location or Time of Sampling	Remarks
Portland Cement Concrete - (All except precast, prestressed, pavement and base)	Cement, Fly Ash, GGBFS	Laboratory Analysis	Materials & Tests	Take a sample upon the initial use of a ready mix facility. This sample will represent any contracts from that ready mix facility for the next 45 days. Any new contracts after 45 days will require a new sample. Additional samples will be required annually for active contracts.	Concrete plant	Must be from approved source. If not, must be tested and approved prior to use.
	Chemical Admixtures	Visual	Project Inspector	Each Design	Mix Design	Must be on approved list and brand shown on Concrete Design. Admixture concentration should be checked.
	Aggregate: Coarse & Fine	Quality	Materials & Tests	One every 6 months or every 200,000 tons from permanent plants. One initially on new or temporary source.	Aggregate plant	Must be from approved source. Also as appearance changes or locations in quarry are changed. Additional samples to be obtained when production exceeds normal output.
		Gradation and Wash	Materials & Tests	1 per month	Concrete plant	Perform wash test on fine aggregate only when percent passing the No. 200 sieve dry exceeds 2.0%
	Reinforcing Steel (Bars)	Laboratory Analysis	Materials & Tests	Verify monthly	In-state fabricator's plant.	Samples should be taken randomly from stock.
Out of state Producer's		Project Inspector	Verify approximately 10% of heat Nos. per shipment.	Project site	Samples should be taken from every shipment.	
Portland Cement Concrete Non-Structural Concrete for <b>Small Quantities</b>	Aggregate: Coarse & Fine	Quality	Materials & Tests	One every 6 months or every 200,000 tons from permanent plants. One initially on new or temporary source.	Aggregate plant	Must be from approved source. Also as appearance changes or locations in quarry are changed. Additional samples to be obtained when production exceeds normal output.
Portland Cement Concrete - Pavement and Base	Cement, Fly Ash, GGBFS	Laboratory Analysis	Materials & Tests	Take a sample upon the initial use of a ready mix facility. This sample will represent any contracts from that ready mix facility for the next 45 days. Any new contracts after 45 days will require a new sample. Additional samples will be required annually for active contracts.	Concrete plant	Must be from approved source. If not, must be tested and approved prior to use.
	Chemical Admixtures	Visual	Project Inspector	Each Design	Mix Design	Must be on approved list and brand shown on Concrete Design. Admixture concentration should be checked.
	Aggregate: Coarse & Fine	Quality	Materials & Tests	One every 6 months or every 200,000 tons from permanent plants. One initially on new or temporary source.	Aggregate plant	Must be from approved source. Also as appearance changes or locations in quarry are changed. Additional samples to be obtained when production exceeds normal output.
		Gradation and Wash	Materials & Tests	1 per month	Concrete plant	Must be from an approved source. Perform wash test on fine aggregate only when percent passing the No. 200 sieve dry exceeds 2.0%
Prestressed Concrete	Cement, Fly Ash, GGBFS	Laboratory Analysis	Materials & Tests	Verify 1 per month.	In-state fabricator's plant.	Must be from approved sources.
	Aggregate: Coarse & Fine	Quality	Materials & Tests	One every 6 months or every 200,000 tons from permanent plants. One initially on new or temporary source.	Aggregate plant	Must be from approved source. Also as appearance changes or locations in quarry are changed. Additional samples to be obtained when production exceeds normal output.
		Gradation and Wash	Materials & Tests	1 per month	Concrete plant	Must be from an approved source. Perform wash test on fine aggregate only when percent passing the No. 200 sieve dry exceeds 2.0%
	Reinforcing Steel (Bars)	Laboratory Analysis	Materials & Tests	Verify a minimum of 10% of heat Nos. used.		Two bars per sample (2ft pieces).
		Out of State Fabricator				
Prestressing Steel Strands	Laboratory Analysis	Materials & Tests	Each Shipment Verify a minimum of 10% of heat Nos. used.	Prestress producers plant	Each reel or pack to have identification tags showing size, grade, and reel number. Each shipment to have stress/strain curves and manufacturers certification. <b>Sample shall consist of 2 strands 42" ± 2".</b>	



**PART THREE: VERIFICATION/CHECK SAMPLES AND TESTS**

Type of Construction	Material	Test	Sampled By	Frequency	Location or Time of Sampling	Remarks
Precast concrete noise wall panels, retaining wall panels, and precast drainage structures including pipes, headwalls, manholes, catch basins, box culverts, and structural spans.	Cement, Fly Ash, GGBFS	Laboratory Analysis	Materials & Tests	1 per month	Precast Concrete plant	Must be from approved source. If not, must be tested and approved prior to use.
	Chemical Admixtures	Visual	Materials & Tests	Each Design	Mix Design	Must be on approved list and brand shown on Concrete Design. Admixture concentration should be checked and compared against design.
	Aggregate - Coarse & Fine	Gradation and Wash	Materials & Tests	1 per month	Precast Concrete plant	Perform wash test on fine aggregate only when percent passing the No. 200 sieve dry exceeds 2.0%
	Reinforcing Steel (Bars)	Laboratory Analysis	Materials & Tests	Verify every 2 weeks.	In-state fabricator's plant.	Samples should be taken from every shipment.
			Materials & Tests	Verify approximately 10% of heat Nos. used.	In-state/Out-of-state fabricator's plant.	
Finished Product	Verification in accordance with SOP 5-3				Must be from approved plant The Frequency of Verification testing will vary at the discretion of the Regional Materials Supervisor. A min. of 1 wet cast and 1 dry cast product per week must be tested. <b><u>Records to be maintained for documentation.</u></b>	
Earth Retaining Structures	Backfill	Quality	Materials & Tests	One every 6 months or every 200,000 tons from permanent plants. One initially on new or temporary source.	Aggregate plant	Must be from an approved source
		Gradation	Materials & Tests	1 @ beginning of Project and then monthly	Aggregate plant or Roadway	
		Proctor/Unit Weight	Materials & Tests	Prior to start or 1 per year		Producer to run gradation weekly as in Quality Control Plan.
	Precast concrete items	Verification in accordance with SOP 5-3				
	Modular Blocks	Strength Absorption	Materials & Tests	Per lot/production run	In-State Producer yard	Verification sampling required for every lot. (One lot consists of a production run) Results of verification test must comply prior to use.
Out-of-State Project Site						
Sub-grade Treatment Lime	Hydrated Lime or quick lime	Laboratory Analysis	Project Inspector	One at beginning of project and 1 per month thereafter per project.	On project before incorporated into work	
Aggregate for Underdrains	Mineral Aggregate	Gradation	Materials & Tests	1 @ beginning of Project and then monthly	Aggregate plant or Roadway	
		Proctor/Unit Weight	Materials & Tests	Prior to start or 1 per year		Producer to run gradation weekly or as stated in Quality Control Plan.
Soil - Cement Base	Cement	Laboratory Analysis	Project Inspector	One at beginning of project and 1 per month thereafter per project.	Mixing Site	Must be from approved source or tested and approved prior to use.
Mineral Aggregate Base & Surface	Aggregate	Quality	Materials & Tests	Once every 6 months from permanent plants. One initially on new or temporary source.	Sampled at source.	Quality report required for each project.
Aggregate Cement Base Course	Aggregate	Quality*	Materials & Tests	Once every 6 months from permanent plants. One initially on new or temporary source.	Sampled at source.	*Only required if blended with a recycled material
	Cement	Laboratory Analysis	Project Inspector	One at beginning of project and 1 per month thereafter per project.	Mixing Site	Must be from approved list and brand shown on concrete design. Add Mixture dose rate should be checked.

**PART THREE: VERIFICATION/CHECK SAMPLES AND TESTS**

Type of Construction	Material	Test	Sampled By	Frequency	Location or Time of Sampling	Remarks
Aggregate - Lime Fly Ash Base Course	Fly Ash Lime	Laboratory Analysis	Project Inspector	One per project.	Mixing Site	Must be from approved source or tested and approved prior to use.
	Aggregate	Quality	Materials & Tests	Once every 6 months from permanent plants. One initially on new or temporary source.	Sampled at source.	Quality report required for each project.
	Hydrated Lime	Laboratory Analysis	Project Inspector	One at beginning of project and 1 per month thereafter per project.	Mixing Site	Must be from approved source or tested and approved prior to use.
Liquid Bituminous Material (All Types)	Performance Graded Asphalt Cement	Complete Analysis	Materials & Tests	Once a month	Asphalt Terminal	Test to be performed at TDOT Headquarters Laboratory. (Excludes all non-critical items for small quantities) Producer to perform compliance test on split sample.
			Project Inspector	Beginning of job and weekly thereafter	Contractor's Storage Tank	
Prime, Tack, Sealer Only	Emulsions	Laboratory Analysis	Project Inspector	At beginning of project, then once per week thereafter.	Distributor Truck	<p>Samples must be received at central lab less than two weeks after sampling. For Field samples, viscosity and residue test to meet specifications, sieve test results &lt; 0.3 will be considered passing. <u>Field samples with sieve results &gt; 0.3 will be evaluated on a case by case basis by the Regional Materials Engineer and the State Bituminous Engineer to determine if the sample passes or fails.</u></p> <p>Failing Test Results for Sieve Tests - Project Supervisor shall make a note as to whether or not an acceptable uniform spread was achieved.</p>
			Materials & Tests	Once a month	Asphalt Terminal	
Bituminous Surface: Surface Treatment, Microsurfacing, Slurry sealing and related similar processes	Aggregate	Quality	Materials & Tests	1 initially from new or temporary plants and 1 every 6 months.	Aggregate plant	Also, test as the appearance changes or location in quarry changes. Additional samples to be obtained when production exceeds normal output. Reports must be issued with initial shipment to project.
	Emulsions	Laboratory Analysis	Project Inspector	One at beginning of project and once per week thereafter	Contractor storage tank	Field samples to meet specifications*. Samples must be received at central lab less than two weeks after sampling. *Sieve test maybe waived for field samples if successful application is achieved in the field.
			Materials & Tests	Once a month	Asphalt Terminal	Terminal samples to verify certifications.
Bituminous Plant Mix Pavements	Plant Mix Asphalt Grading B, BM, BM2, C, CW, D, E, CS, TLD, and TL	Air Voids (T166, T209, T269)	Project Inspector	During Test Strip Construction or Mix Verification.	Completed mix in truck or on roadway.	Projects with less than 1000 tons of asphalt shall be exempt from verification testing.
	Aggregate	Quality	Materials & Tests	One every 6 months or every 200,000 tons from permanent plants. One initially on new or temporary source.	Aggregate plant	Also, test as appearance changes or locations in quarry are changed. Additional samples to be obtained when production exceeds normal output.

# 12

**Standard Operating**

**Procedure 7-1**

**(SOP 7-1)**

**Tennessee Department of Transportation  
Division of Materials and Tests**

**Nuclear Density Testing (SOP 7-1)**

**Purpose:** The purpose of this document is to provide guidance for conducting nuclear density tests on hot mix asphalt, backfill, soil, aggregate base, embankments, and other materials requiring density tests in accordance with SOP 1-1.

**Discussion:** Many compacted materials on TDOT projects are accepted by means of testing with nuclear density gauges. This document intends to provide guidance and define best practices for operation of these gauges to unify testing operations statewide. Testing details of common concern include proper setup of gauge information, depth of test probes, time length of tests, and recording of data.

**Basic Procedure:** All test procedures shall be in accordance with AASHTO T310, "*In-Place Density and Moisture Content of Soil and Soil-Aggregate by Nuclear Methods (Shallow Depth)*" and ASTM D2950, "*Standard Test Method for Density of Bituminous Concrete In-Place by Nuclear Methods*" except as revised herein.

Specific instructions on conducting standard counts, entering maximum specific gravity values, offsets, correction factors, and proctor information can be found in the users' manuals corresponding to the make and model of the gauge in use.

**PART ONE – ACCEPTANCE TESTING**

**Hot Mix Asphalt**

*Mixtures: 307-A, 307-B, 307-BM, 307-BM2, 307-C, 307-CW, 411-D, 411-Es*

**Step 1:** Conduct Standard Count

**Step 2:** Enter maximum specific gravity (Gmm) value from asphalt mix design.

**Step 3:** Enter gauge correction factor from test strip. See Part Two for determining correction factors.

**Step 4:** Set gauge setting to Backscatter.

**Step 5:** Place gauge in location to be tested.

**Footnote 1:** For guidance on testing frequencies, random numbers, and selecting test locations, see [SOP 1-1](#).

Step 6: Activate a test. When collecting a density test, the following approach shall be used:

- “*Four Nineties*” Test: Four tests may be conducted at a single location, rotating around the test location 90 degrees at a time, as shown in Figure 1. The four test results will then be averaged to obtain a single test value for that location. Test counts for this approach should be 15 seconds or longer.

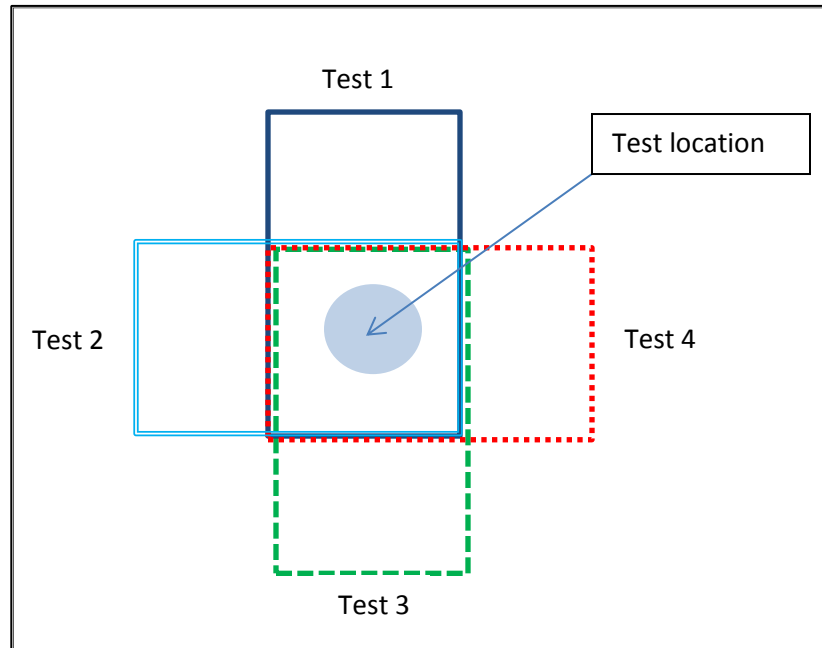

*Figure 1. Testing at four 90° locations*

Step 7: Record the test value into the appropriate paperwork.

- DT-0315, Daily Asphalt Density Report

## Soil and Aggregate Materials

*Materials: Backfill (Earth retaining structures), Select granular backfill (Earth retaining structures), Embankments, Subgrade preparation, Lime-treated subgrade, Soil-Cement Base, Mineral Aggregate Base and Surface, Aggregate for Underdrains, Aggregate-Cement base course, Aggregate Lime fly ash base course, & Conditioned mineral aggregate base.*

Step 1: Conduct Standard Count

Step 2: Enter maximum dry density and optimum moisture content from Proctor Density report.

Step 3: Select Test location. Create a test hole using the scraper plate and drill rod provided with the gauge.

**Footnote 2:** For guidance on selecting test locations, see [SOP 1-1](#).

Step 4: Set gauge setting to Direct Transmission at a depth reasonably close to one half the depth of the compacted lift.

Step 5: Place gauge in location to be tested and insert test probe into test hole at a depth reasonably close to one half the depth of the compacted lift. Pull gauge back to ensure probe makes contact with material being tested.

Step 6: Activate a test. When collecting a density test, the following approach shall be used:

*Single Count Test:* A single test may be conducted at any test location, given that the test count is greater than or equal to 60 seconds.

Step 7: Record the test value into the appropriate paperwork.

- DT-0298, Daily Report on Soil and Aggregate Stabilization
- DT-0304, Daily Report on Embankment
- DT-0307, Daily Report on Mineral Aggregate Base
- DT-0314, Density Worksheet – Nuclear Method (Aggregate, Soil)

## PART TWO – DETERMINATION OF ASPHALT CALIBRATION FACTORS

- Conduct test strips in accordance with most current version of TDOT Standard specifications, subsection 407.15
- Test strips are required for the following mixtures:  
*307-A, 307-B, 307-BM, 307-BM2, 307-C, 307-CW, 411-D, 411-Es*
- The minimum size of a single test strip is 400 yd<sup>2</sup>, but a larger area is recommended. The following roadway lengths provide an area of 400 yd<sup>2</sup> :
  - 9' wide= 400' long
  - 10' wide= 360' long
  - 11' wide= 330' long
  - 12' wide= 300' long
- Compaction of the test strip shall commence immediately after placement of the bituminous mixture.
- TDOT form DT-0316, Density and Roller Pattern Test Strip

Step 1: After a single pass of the breakdown roller, conduct a density test in accordance with Part One, above. Record the uncorrected test value in lbs/ft<sup>3</sup>.

Step 2: After a second pass of the breakdown roller, conduct a second density test and record the uncorrected test value in lbs/ft<sup>3</sup>.

Step 3: Repeat the roller pass/testing process until a value is obtained that does not increase from the previous pass more than 1 lb/ft<sup>3</sup>. This number of passes or the pass before it shall be the target number of passes for the breakdown roller.

Step 4: After compacting an additional area with the breakdown roller at the correct target number of passes, repeat steps 1-3 for the intermediate roller.

Step 5: After compacting an additional area with the breakdown and intermediate rollers at the correct target number of passes, repeat steps 1-3 for the finish roller. Often times, the resulting target number of passes will only be 1 or 2 passes for finish rollers.

Step 6: Compact test strip area with all three rollers at the correct target number of passes.

Step 7: Layout test strip test locations and conduct and record ten uncorrected density tests on the compacted test strip area and record test information

Step 8: Cores should be cut at same locations as nuclear density tests and tested by TDOT Plant Technician for laboratory density in accordance with AASHTO T166.

**Footnote 3:** Only Method A of T166 shall apply when testing test strip cores for density. Cores shall be COMPLETELY DRY before testing. Accelerated drying in accordance with ASTM D 7227 (core drying device) is permitted.

Step 9: The nuclear gauge correction factor shall be the difference between the average of ten nuclear gauge readings and the average of ten core density values.

**Additional notes on test strips and correction factors:**

- Nuclear gauges are specific to an individual gauge, mix, and project. It is poor practice to develop a correction factor with a different gauge unit than the one to be used during mainline acceptance testing.
- Developing correction factors based on cores that were not allowed to dry completely will influence results in a manner that can mislead test results into appearing as if they are higher than they actually are. In other words, wet cores appear heavier or denser than they actually are.
- In accordance with TDOT Specifications, a new test strip is required when:
  - There is a change in job mix formulas
  - A change in the source of materials occurs
  - A change in the material from the same source is observed
  - There is reason to believe that the test strip density is not representative of the mixture being placed. For example, test results are consistently above 100% density or test results have been consistent for a steady number of days and had suddenly changed significantly.
  - A change in paving or compaction equipment occurs.
- Test variables selected during test strips (i.e. - length of count, single test for 60 seconds, testing at “four 90’s”, backscatter, driving test holes, etc) must be consistent between what is chosen during development of correction factors and what is done during subsequent acceptance testing. *i.e. – If a correction factor is set up by testing 307A mix in backscatter, then all acceptance tests using that correction factor must be tested in backscatter.*
- When testing large aggregate mixtures such as 307-A mixture that have a large amount of surface texture, clean natural sand may be spread to fill surface voids prior to testing.



# 13

**Standard Operating**

**Procedure 7-2**

**(SOP 7-2)**

**Tennessee Department of Transportation  
Division of Materials and Tests  
Standard Operating Procedure 7-2  
Nuclear Gauge Safety Plan**

**Purpose** - The purpose of this document is to establish guidelines on nuclear density gauge daily usage, gauge transportation, and outline an Emergency Response Plan for TDOT Radiation Safety Technicians. A TDOT Radiation Safety Technician is an individual who has successfully completed the TDOT Radiation Safety training and demonstrated a basic understanding of: radiation safety and compliance, nuclear density gauge operation, testing procedures, and maintenance.

**Background**- Tennessee Radioactive Material License No. R-19017-K16 requires that TDOT technicians attend the appropriate training to operate and transport nuclear density gauges. The license also requires TDOT to have a radiation safety emergency response plan.

Each Regional Materials and Tests Office has a regional Radiation Safety Officer (RSO) in the Materials and Tests Office as well as the Statewide RSO in Headquarters Materials and Tests. Each gauge operator is responsible for knowing the current contact information of their regional RSO.

## **1 Storage Site**

- 1.1 The handle shall be locked and the gauge stored in its transport case.
- 1.2 The transport case shall be locked.
- 1.3 The gauge and transport case shall be stored at least 15ft (5 m) from work areas, in a locked closet/storage area in a dry location (indoors).
- 1.4 The storage area shall be marked with a radiation sign that reads "**CAUTION RADIOACTIVE MATERIALS**" (can be obtained from HQ RSO).
- 1.5 Do not store a nuclear gauge in a motor vehicle except:
  - 1.5.1 The nuclear gauge may be stored inside the gauge operator's truck when not in use on a construction site or at a location in transit between the permanent storage site and the project site. With permission of the gauge operator's supervisor, the gauge operator may store the gauge overnight in their truck, provided it is secured per section 4, at a location between the permanent storage site and the project site. In all other cases the gauge operator shall return the gauge to the permanent storage location.
  - 1.5.2 Any time the gauge is stored in the truck it shall be secured for transport per section 4.
- 1.6 A log of all gauges stored at the site will be maintained at the storage site. All gauges must be checked in when not stored and checked out by the operator when in use.
- 1.7 Storage site must be enclosed (four walls and a roof) and it must protect gauges from the elements.
- 1.8 Only nuclear gauges are allowed to be stored inside the storage site. No tools/equipment/debris of any kind is allowed to be placed inside the storage site.

## **2 Inspections:**

- 2.1 Inspect the gauge before use to ensure proper operation of all safety features as follows:
  - 2.1.1 Push the source rod down into the backscatter position, and then raise it back to the SAFE (shielded) position. The source rod opening in the bottom of the gauge is equipped with a spring- loaded tungsten sliding block that shuts when the source rod is in the SAFE position. Turn the gauge over and verify that the sliding block is completely shut.

If any portion of the opening is uncovered, the clean the sliding block before using, transporting, or storing the gauge.

2.1.2 Do not store or transport the gauge unless the sliding block is completely closed. Increased radiation levels may violate transportation regulations and cause excessive personal radiation exposure.

2.1.3 If a radiation survey instrument is available, verify that the radioactive gamma source is in place by measuring the exposure rate at the surface of the gauge. If the exposure rate is not in the approximately range of 10 - 20 mrem per hour contact the regional RSO and discontinue use of the gauge until further notice.

## 2.2 Biannual Inspection

2.2.1 Gauges shall be leak tested every April and October. The Regional RSO shall conduct a 'swipe' test and submit the sample to the HQ RSO who will submit all samples to the lab for testing. In conjunction with the 'swipe' test, an inventory check must be completed. This means that the gauge must be physically located and accounted for.

## 3 Operator Certification and Monitoring:

3.1 Anyone operating a nuclear gauge shall be a certified TDOT Radiation Safety Technician.

3.2 The technician must wear their assigned dosimeter while operating or transporting the nuclear gauge. Dosimeter may not be shared between individuals and may only be used by the person who is named on the dosimeter.

3.3 Badges shall be turned in every March, June, September, and December to the regional RSO to be checked for individual exposure.

## 4 Transporting Nuclear Gauge to Project

4.1 The handle for the gauge shall be locked into the safe position during transport.

4.2 The nuclear gauge shall be locked inside the transport case during transport.

4.3 Transport the nuclear gauge in the rearmost part of the bed of a truck inside either:

4.3.1 a locked bed cover with the device secured in place with heavy chain to prevent the case from moving or

4.3.2 a mounted transportation box, specifically designed for the nuclear gauge case.

4.4 No one other than the operator of the nuclear gauge is allowed in the vehicle while the nuclear gauge is in the vehicle.

4.5 While in transit the following paperwork must be in the vehicle and readily accessible by the driver:

- nuclear gauge bill of lading (BOL),
- operator's nuclear safety certificate,
- nuclear gauge shipping paper,
- TDOT Radiation Safety Plan (SOP 7-2),

4.6 At any time the vehicle is parked while the gauge is stowed for transit, the shipping paper must be placed face up in the driver's seat.

## 5 Operating Nuclear Gauge at the Project

5.1 See SOP 7-1 for instructions on how to calibrate and run tests.

5.2 Only remove the nuclear gauge from the truck when testing is eminent.

- 5.3 If the gauge is unsecured (i.e. not stored for transport per section 4 or stored per section 1), it shall be in the possession of the operator. The nuclear gauge shall never be left unattended on site.
- 5.4 If it becomes necessary to move between locations inside the project, lock the handle into the SAFE position and replace the nuclear gauge into the transport case and place in the rear of truck bed. At no time shall the nuclear gauge be placed into the cab of the truck.
  - 5.4.1 It is not necessary to lock the case and bed cover for short trips inside the project limits
- 5.5 When the nuclear gauge is in operation all personnel besides the operator must be a minimum of 30' away from the gauge.
- 5.6 Once the operator has set the gauge and it is reading, the operator shall walk a minimum distance of 30' away from the gauge.

**6 Emergency Response Plan:** In the case of accident, damage, loss, or theft of nuclear gauge adhere to the following procedure:

**6.1 Priority Response Actions To Be Taken By Gauge Operator**

- 6.1.1 **FIRST PRIORITY:** Render aid as necessary for lifesaving, first aid, control of fire and other hazards. (Note: Radiation presents minimal risks to lives of persons during transportation accidents. Packages identified as "Type A" by markings on the shipping containers contain only non-life endangering amounts of radioactive materials.)
- 6.1.2 **ADDITIONAL ACTIONS BY GAUGE OPERATOR:**
  - 6.1.2.1 Visually inspect gauge for damage, including visual inspection of source rod. Determine if sources are, or can be placed in their shielded positions.
  - 6.1.2.2 Locate sources if separated from the gauge. **DO NOT TOUCH OR MOVE RADIOACTIVE SOURCES.** Locate, mark, and secure but do not pick up with bare hands.
  - 6.1.2.3 Secure Area – Evacuate an area of at least a 15 ft. radius around the damaged gauge and/or radioactive sources. (Note: if a source cannot be located, THEN evacuate and secure an area large enough to include any possible locations where the source might be located. Prevent entry by all unauthorized persons into the evacuated area.
  - 6.1.2.4 If a vehicle or construction equipment is involved in the incident, detain the equipment until it is determined that there is no contamination.
  - 6.1.2.5 As soon as possible after these actions have been accomplished, notify the RSO of the incident.
  - 6.1.2.6 Describe in detail the incident, condition of the gauge, and actions taken. Follow any additional instructions given by the RSO as soon as possible.

**6.2 Response Actions to Be Taken by the Regional RSO**

- 6.2.1 Give additional advice to gauge operator (if needed).
- 6.2.2 Notify the police, fire, or other emergency agencies as needed or required.
- 6.2.3 Notify the HQ RSO
- 6.2.4 The HQ RSO will notify the Tennessee Department of Environmental Conservation Division of Radiological Health at (615) 532-0364.
- 6.2.5 The HQ RSO will notify the following as needed or if required:
  - TEMA
  - 1 (800) 262-3300
  - Troxler 24-Hour Hazmat Emergency
  - (919) 549-9539

Humboldt 24-Hour Hazmat Emergency

1 (800) 535-5053

U.S. DOT

1 (800) 424-8802

- 6.2.6 Travel to the accident site and perform the following:
  - 6.2.6.1 Confirm the actions taken by the operator to be correct.
  - 6.2.6.2 Conduct a visual inspection of the gauge, shielding, and source rod to determine if radioactive sources are still in the gauge.
  - 6.2.6.3 If radioactive sources are found to be missing, or damage to the shielding is suspected:
    - 6.2.6.3.1 Use survey meter to conduct a radiation survey of the gauge to assess the integrity of the source encapsulation and shielding. Compare the survey radiation levels to the gauge radiation profile. If the any reading is greater than the listed values you can suspect that the source shielding has been violated.
    - 6.2.6.3.2 If source(s) are not present in the gauge, perform the necessary surveys to locate and properly secure the source(s). ( Note: DO NOT pick up radioactive sources with your hands. Use tongs or pliers to place the source in a properly shielded container. Container may be a source “pig”. The source may also be returned to the gauge shielding if uncompromised.
    - 6.2.6.3.3 Perform a leak test on the gauge and source rod.
    - 6.2.6.3.4 With gauge sources at least 30 feet away, check leak test filters with a survey meter and proceed as follows: If the wipe shows a reading greater than background reading, STOP all other actions. Leave any suspected contaminated material in the secured area and notify the appropriate regulatory agency. Increase the secured area and maintain security until proper authorities arrive.
    - 6.2.6.3.5 If no contamination is found, notify the Regional RSO and request permission to transport the gauge. Once gauge has been approved for transporting, any involved vehicle or equipment may be released and the secure area re-opened.
    - 6.2.6.3.6 Document all actions taken, or not taken, and provide sketches and/or photos.

**6.3 Follow Up Actions Taken By Regional Radiation Safety Officer**

- 6.3.1 Take photos of the damaged gauge prior to shipping for repairs or disposal.
- 6.3.2 Place gauge in secure storage location until approved for shipment to manufacturer if needed.
- 6.3.3 Notify the gauge manufacturer of gauge damage and accident.
- 6.3.4 Send photos of the gauge along with leak test info to the manufacturer for clearance and shipping instructions.
- 6.3.5 Document any actions and instructions given for records.
- 6.3.6 Notify by telephone or mail/email ALL regulatory agencies as required of post-accident corrective actions and safety precautions taken.
- 6.3.7 Ship the damaged gauge to manufacturer per instructions given. (Note: NEVER ship a damaged nuclear gauge until it has been leak tested and the wipe cleared.

- 6.3.8 Review accident causes and measures taken. Establish new or revised guidelines to prevent similar future occurrences.

# 14

**TDOT**

**Standard Specifications**

**January 1, 2015**

**Section 205 – Embankments**

**Section 303 – Mineral Aggregate Base**

## **SECTION 205 – EMBANKMENTS**

205.01 Description .....	172
205.02 Materials .....	172
205.03 Preparation of Embankment Areas.....	173
205.04 Formation of Embankments .....	174
205.05 Stability of Embankments and Cut Slopes .....	178
205.06 Disposal of Excess or Unsuitable Material .....	178
205.07 Method of Measurement .....	178
205.08 Basis of Payment.....	179

### **DESCRIPTION**

#### **205.01 Description**

This work consists of constructing roadway embankments, including preparing the area upon which they are to be placed; constructing dikes within or outside the right-of-way; placing and compacting approved material within roadway areas where unsuitable material has been removed; and placing and compacting embankment material in holes, pits, and other depressions within the roadway area.

### **MATERIALS**

#### **205.02 Materials**

For embankment and backfill, only use approved materials, consisting of Road and Drainage Excavation, Channel Excavation, and Borrow Excavation material as specified in **203**, or excess material as specified in **204**.



## CONSTRUCTION REQUIREMENTS

### 205.03 Preparation of Embankment Areas

Before beginning embankment construction in any area, complete Clearing and Grubbing, Removal of Structures and Obstructions, and installation of preliminary erosion control measures according to the approved SWPPP as specified in **201**, **202**, and **209** respectively.

Address both natural and created steep slope areas as required in the TN Construction General Permit. Maintain and stabilize steep slopes according to the TN Construction General Permit and all applicable environmental permits.

Remove snow, ice, and mud before placing embankment materials on the ground. Do not place embankment materials on top of ground surfaces and existing embankment layers that are frozen.

Fill all depressions or holes below the natural ground surface, whether caused by grubbing or otherwise, with suitable material and compact to the ground surface before starting embankment construction.

Unless otherwise shown on the Plans or specified in the Special Provisions, if constructing embankment of less than 3 feet below subgrade:

1. Remove all sod and vegetable matter from the surface.
2. Remove unsuitable material and replace with suitable material.
3. Break up the cleared surface by plowing, scarifying, or stripping to a minimum depth of 6 inches, and then re-compact this area.
4. Cultivate sod not required to be removed before constructing the embankment.
5. If a compacted road surface containing granular materials lies within 3 feet of the subgrade, scarify the old road surface to a depth of at least 6 inches, and then re-compact the scarified material.

Remove and dispose of concrete pavement, parking strip, and base, all with or without bituminous overlay, concrete curb and gutter, sidewalk,

driveways, and similar features as specified in **202.06** or as otherwise directed by the Engineer.

When placing embankment material on or against existing slopes that are steeper than 4:1, cut benches into the existing slope while bringing up the new embankment material in layers. Cut each bench of sufficient width to accommodate the operation of placing and compacting equipment. Begin each successive cut at the intersection of the original ground and the vertical side of the previous cut. Re-compact the cut material along with the new embankment material at no additional cost to the Department.

Before placing embankment material on a structure or any unit of a structure, ensure that the surrounding backfill has been completed and thoroughly compacted to ground surface.

#### **205.04 Formation of Embankments**

Do not incorporate or bury any perishable materials, such as brush, hedge, roots, stumps, and parts of trees, in the embankments. Do not place rock, broken concrete, or other solid objects in embankments areas where piling will be installed.

Construct embankments so as to provide adequate surface drainage at all times. If roadway embankment materials consist predominantly of soil, place the material in horizontal layers not to exceed 10 inches in loose thickness, and compact each layer to a density not less than 95% of maximum density. Unless otherwise specified, compact the top 6 inches of the roadbed in both cut and fill sections to 100% of maximum density.

The Engineer will determine maximum density and optimum moisture according to AASHTO T 99. For material with less than 5% retained on a No. 4 sieve, method A with 4-inch mold will be used. For material with more than 5% retained on a No. 4 sieve but less than 50% retained on a 3/4-inch sieve, Method D with corrections according to AASHTO T 224 will be used.

Use the correction on soils containing less than 50% plus 3/4-inch material.

Determine the density of the soil in place according to an approved AASHTO method. Compact each embankment layer to the required density, and obtain the Engineer's approval before placing material for the next succeeding layer. Keep placing and compacting areas separate.

If the Contract includes the placement of base stone or other components of a pavement structure upon the subgrade, compact the top 6 inches in both cut and fill sections to a density equal to 100% of the maximum density as specified in **207.04**.

When constructing embankment across low swampy ground that will not support earth moving equipment, construct the lower part of the fill in a uniformly distributed layer of a thickness not greater than necessary to support the hauling equipment while placing subsequent layers. Construct the embankment full width unless otherwise shown on the Plans or approved by the Engineer. The Engineer will waive the density requirement for such a lift, but the moisture content of the material used shall not exceed the optimum moisture range for 95% density for that material. Comply with the maximum thickness and minimum density requirements for all succeeding layers of the embankment.

When a minimum of 95% of maximum density is required, ensure that the moisture content of the material being compacted meets both of the following conditions:

1. The moisture content shall be within the range of values at which 95% of the maximum density can be obtained as indicated by the moisture-density relationship curve; and
2. The moisture content shall not exceed the optimum moisture content to the extent that the material pumps under loads applied by the construction equipment.

Even if the required density is achieved and the moisture content is in range, if pumping occurs, remove the affected sections.

When 100% of maximum density is required, the moisture content of the material being compacted shall meet condition (2) above and shall not vary from the optimum moisture content by more than  $\pm 3\%$ .

Aerate the material, or distribute and incorporate water uniformly into the material, as necessary, to control the moisture content within the applicable limits.

If the excavated material consists predominantly of rock, the following shall apply:

**A. Definition of Material**

If deemed necessary by the Engineer, the Contractor shall conduct test or tests with a 60,000-pound static tamping foot roller (costs to be included in other items) to determine whether the material is degradable or non-degradable. Consider material that readily breaks down under three passes of the 60,000-pound static tamping foot roller as degradable.

**B. Non-Degradable Rock**

If sound, non-degradable rock is encountered in the unclassified excavation, the Engineer may require the Contractor to provide a mechanical means for separating the sound rock from degradable rock and other soils. The Engineer may allow the use of sound, non-degradable rock in the backfilling of benches, lower and outside portions of embankments, rock buttresses, or other areas.

If the material for embankments consists of sound, non-degradable rock of a size that makes placing the material in 10-inch layers impracticable, place the material in layers no thicker than 3 feet. Do not use rock fragments greater than 2 feet in maximum dimension. With the Engineer's approval, the Contractor may place occasional individual rocks and boulders not exceeding 4 feet in height in the exterior portions of the embankment next to the slope face. Place such rocks to prevent nesting, and fill the adjacent voids with fine fragments to form a dense and compact mass.

Do not dump rock material into its final position. Place rock by blading or dozing in a manner that will minimize voids, pockets, and bridging. Ensure that each layer is leveled the full width of the embankment. Rolling is not required if the rock embankment consists of sound, non-degradable material placed in greater than 10-inch layers.

**C. Degradable Rock**

Compact degradable rock for use in embankment with an approved vibratory tamping-foot roller in conjunction with a static tamping-foot roller. The minimum weight for the static tamping-foot roller shall be 60,000 pounds. The minimum compaction effort, as rated by the manufacturer, for the vibratory tamping-foot roller shall be 55,000 pounds. Submit roller specifications to the Engineer for approval before use.

Place degradable rock in 10-inch maximum loose lifts, and provide a minimum of three passes with the static roller and two passes with the vibratory roller. The Engineer may direct additional passes with either or both rollers until satisfactory breakdown and compaction is accomplished. Do not place degradable rock in the top 5 feet of an embankment unless approved by the Engineer.

If embankment composed of degradable rock does not contain sufficient moisture to compact properly, the Engineer will require the Contractor to apply water in sufficient quantities to achieve the approximate optimum moisture for the particular material involved. Uniformly mix the added water with the material for the entire depth of the lift by blading, discing, or other approved methods.

#### **D. Combination of Degradable and Non-Degradable Rock**

Do not blend or combine degradable rock and non-degradable rock in a common lift without the Engineer's written approval.

If approved, place embankment material consisting of a mixture of degradable rock and non-degradable rock, or rock and soil, in layers not exceeding 10 inches in thickness unless otherwise directed by the Engineer. If the combined material is predominantly sound, non-degradable rock with fragments thicker than 10 inches, the Engineer may increase the layer thickness to be consistent with the size of the material, not to exceed 3 feet. Place the mixture by blading or dozing in a manner that will minimize voids, pockets, and bridging. Compact the mixture with suitable compaction equipment as defined in **205.04.A**, and apply water to facilitate compaction as directed by the Engineer. Uniformly mix the added water with the material for the entire depth of the lift by blading, discing, or other approved methods.

#### **E. Density Requirements**

Density requirements will not apply to portions of embankments constructed of materials that cannot be tested by approved methods.

When the Plans require Solid Rock Fill, the material shall consist of sound, non-degradable rock (granite, gneiss, limestone, or other approved material). When the material is subjected to five alternations of the sodium sulfate soundness test performed according to AASHTO T 104, the weighted percentage of loss shall not exceed 12. Do not use plastic soil or

shale material. Place Solid Rock Fill as shown on the Plans or as directed by the Engineer.

Construct the roadway through rock fills to the grading line shown on the Plans with an allowable working tolerance of plus 1 to minus 3 inches. Bring up to grade those portions of the roadway that are then below grade with spalls or other suitable granular material that is available from the excavation within the balance. If no such excavation is available, the Engineer may direct the Contractor to use approved base material for bringing the fill to grade, not to exceed the specified 3-inch limit.

If embankment material is to be placed on both sides of a concrete wall or box type structure, bring the material up equally on both sides of the structure.

At the location of abutments, bents, and similar features, construct embankment to the finished grade before starting excavation on the respective section of the substructure, unless otherwise shown on the Plans. If embankment material is to be placed on only one side of abutments, wing walls, piers, and similar features, do not begin construction until the superstructure is in place. Perform compaction operations without causing wedge action or placing excessive pressure against the structure.

#### **205.05 Stability of Embankments and Cut Slopes**

Assume responsibility for the stability of all embankments and cut slopes until final acceptance. Replace, at no additional cost to the Department, all portions which, in the Engineer's opinion, have become displaced or damaged due to carelessness or negligence.

#### **205.06 Disposal of Excess or Unsuitable Material**

Dispose of excess or unsuitable material as specified in **203.07**.

### **COMPENSATION**

#### **205.07 Method of Measurement**

The Department will not measure embankment. The Contractor shall construct embankments under the items described in **203** and **204** that apply to the materials used to construct the embankments.

The Department will measure excavation to bench side-hill slopes for embankment construction in accordance with **203.09.A.2**.

#### **205.08 Basis of Payment**

The Department will not directly pay for embankments. The contract unit prices for the materials with which embankments are acceptably constructed is full compensation for all embankment construction, including materials, equipment, labor, and incidentals to complete the work as specified.

If the Contractor encounters pumping of soil despite having achieved the required density and moisture content, the Department will pay for the removal of these sections as Undercutting by the cubic yard in cut sections only. No such payment will be made in fill sections.

If the excavated material consists predominantly of rock, the Department will pay for water required and provided by the Contractor to facilitate compaction at the unit price per M.G. (1,000 gallons) for Water, which price is full compensation for furnishing and applying the water, mixing, labor, and equipment. The Department will consider all other costs associated with the constructing embankment of material consisting predominantly of rock, including providing suitable compaction equipment and separating sound rock from degradable rock and soils, as included in the unit price for Road and Drainage Excavation (Unclassified).

If the Engineer directs the Contractor to use approved base material to bring portions of the roadway that are less than 3 inches below grade up to grade, the Department will measure and pay for the furnishing and placing of such base material in tons under the applicable item in **303.15**. If base material is not a bid item in the Contract, the Contractor shall provide the material under the provisions of **104.02.D**.

If, despite proper construction and protection, damage to the embankments or cut slopes occurs due to unusual natural causes such as cloudbursts, floods, slides or subsidence, the Department will pay for the material used to make the necessary repairs at the contract unit price for the material classification designated by the Engineer to be used for this purpose. The Department will pay for removal of slides in accordance with **203.10**.

## SECTION 303 – MINERAL AGGREGATE BASE

303.01	Description .....	220
303.02	Aggregate .....	220
303.03	Calcium Chloride .....	221
303.04	Sodium Chloride .....	221
303.05	Emulsified Asphalt.....	221
303.06	Equipment .....	221
303.07	General.....	222
303.08	Mixing.....	223
303.09	Spreading .....	224
303.10	Shaping and Compaction .....	225
303.11	Maintenance .....	227
303.12	Thickness Requirements .....	228
303.13	Surface Requirements .....	228
303.14	Method of Measurement .....	228
303.15	Basis of Payment.....	229

### DESCRIPTION

#### 303.01 Description

This work consists of furnishing and placing one or more courses of aggregates, and additives if required, on a prepared subgrade.

Mineral aggregates base shall be Type A or Type B, whichever is shown on the Plans and called for in the bid schedule.

### MATERIALS

#### 303.02 Aggregate

Depending upon whether the Plans require Type A or Type B base, provide mineral aggregate meeting **903.05**. For Type A base, use aggregate of



Grading D. For Type B base, the Contractor may use aggregate of Grading C or D.

The Engineer will accept aggregate for gradation as follows:

1. When the stationary plant method for mixing is used, the Engineer will accept aggregate immediately after or prior to mixing, based on periodic samples taken from the pugmill output or from the belt feeding the pugmill.
2. When two or more materials are blended on the road using mechanical mixers, the Engineer will accept aggregate after mixing and before compaction, based on samples taken from each layer of base material.
3. For aggregate that does not require blending, the Engineer will accept aggregate at the aggregate production plant, based on samples taken from stockpiles of plant production immediately before delivery to the road.

### **303.03 Calcium Chloride**

Provide calcium chloride meeting **921.02** for Type 1, Type 2 or calcium chloride liquor.

### **303.04 Sodium Chloride**

Provide sodium chloride meeting **921.03**.

### **303.05 Emulsified Asphalt**

Use emulsified asphalt of a type allowed for Prime Coat in **401**, meeting the test requirements specified in **904.03**.

## **EQUIPMENT**

### **303.06 Equipment**

Provide a stationary mixing plant, mechanical road mixer, or motor grader, whichever is applicable to the type of work to be performed, as specified in **303.08**.

**A. Stationary Mixing Plant**

Provide an approved twin-shaft pugmill capable of producing a constant, uniform mixture. Equip the mixing plant with the following:

1. A suitable truck-loading hopper with a gate that will prevent segregation of the material when dumped into the truck;
2. A spray bar, capable of ensuring an even wetting of the aggregate, mounted at the entrance of or above the pugmill;
3. A meter, valve, or other approved type of regulating device to control the flow of water through the spray bar to maintain a uniform moisture content in the mixture;
4. A separate, quick, and automatically operating on-and-off device to shut the water off instantly when the pugmill stops; and
5. Adjustable mechanical feeders for each size material capable of regulating a constant, uniform flow of material.

**B. Mechanical Mixer (for Road Mixing)**

Provide a pugmill or rotary type mechanical mixer capable of producing a uniform blend of all materials to the full depth of the course being placed. The mixer may be either self-propelled or trailer-drawn.

**C. Compaction Equipment**

Provide one or more rollers of a type and sufficient weight to obtain the required density and seal the surface of the base course.

**CONSTRUCTION REQUIREMENTS**

**303.07 General**

Construct Mineral Aggregate Base, Type A or Type B, in one or more layers, to the compacted thickness shown on the Plans.

Prepare the subgrade as specified in **205**, **207**, or **302**, whichever is applicable.

Obtain the Engineer's approval of the subgrade before spreading any mineral aggregate. Subgrade that has been previously checked and approved, but subsequently subjected to freezing conditions or prolonged wet weather, shall be rechecked for approval.

Do not spread mineral aggregate on a subgrade that is frozen or contains frost.

Do not haul over any material that has been placed until it has been spread, mixed, shaped and compacted to the required density.

### **303.08 Mixing**

#### **A. Mixing Methods**

Unless otherwise specified, mix the base course material, including an additive if shown on the Plans, by one or more of the following three methods:

- 1. Stationary Plant Method.** Mix the base course material and water in an approved stationary mixing plant as specified in **303.06.A**. Add sufficient water during the mixing operation to provide a moisture content satisfactory for compacting. If combining materials to meet the grading requirements, blend the materials, as specified in **903.05**, before mixing. Ensure that all material fed into the plant travels the full length of the pugmill.
- 2. Road Mix Method (Mechanical Mixer).** After placing the material for each layer of base course through an aggregate spreader or windrow-sizing device, mix the material using approved mechanical mixing machines as specified in **303.06.B**.

During mixing, add sufficient water to provide a moisture content satisfactory for compacting.

- 3. Road Mix Method (Motor Grader).** After depositing and uniformly spreading material for each layer of base course, sprinkle it with just enough water to moisten all particles, but without causing segregation of sizes or softening of the subgrade. Immediately after applying water, thoroughly mix the material by

windrowing and spreading with motor graders until the mixture is uniform throughout.

For Mineral Aggregate Base, Type A, use the stationary plant method. For Mineral Aggregate Base, Type B, requiring the blending of two or more materials, use either the stationary plant method or the road mix method (mechanical mixer), except as provided for in **903.05**. For Mineral Aggregate Base, Type B, requiring additive, use either stationary plant mixing or road mixing.

#### **B. Use of Calcium Chloride and Sodium Chloride**

If using calcium chloride, incorporate it in either the solid or liquid form, at the approximate rate of 6 pounds per ton of aggregate, noting that:

- 6 pounds is equivalent to 1.29 gallons 60 °F 32% solution
- 6 pounds is equivalent to 1.02 gallons 60 °F 38% solution

If using sodium chloride, incorporate it at the approximate rate of 5 pounds per ton of aggregate.

For stationary plant mixing, proportion chloride material, in solid form, through a hopper equipped with an approved vibratory feeder and an adjustable opening capable of accurately controlling the flow of material. Proportion calcium chloride liquor using an approved calibrated meter that has a registering capacity capable of indicating the total amount of liquid used during any single day's operation.

For road mixing, add the chloride material to the aggregate at the point in the mixing operation and in the manner directed by the Engineer.

#### **303.09 Spreading**

Spread material as follows according to the mix method used:

##### **A. Stationary Plant Mixing**

After mixing, transport material to the site for each layer of base while it contains the proper moisture content. Spread the material to the required thickness and cross-section using an approved mechanical spreader.

**B. Road Mixing (Mechanical Mixer)**

Before mixing, spread material with an approved mechanical spreader that can be adjusted to spread materials in the proper proportions.

**C. Road Mixing (Motor Grader)**

After thoroughly mixing the aggregate and water, spread the base material while at optimum moisture content in layers of specified thickness and cross-section using approved motor graders.

If the required compacted depth of the base course exceeds 6 inches, construct the base in two or more layers of approximate equal thickness. The maximum compacted thickness of any one layer shall not exceed 6 inches; however, if vibrating or other approved types of special compacting equipment are used, the Contractor may increase the compacted depth of a single base course layer to 8 inches with the Engineer's approval.

In some cases, the Plans may show the base as extending for the full width of the roadbed. In other cases, the edges of the base may be shown as coinciding with the inside edges of the shoulders. In the latter case, place shoulder material to a minimum width of 3 feet before spreading each layer of base material in order to confine the base material and to allow for proper compaction.

The Contractor may spread and mix any base material used for constructing detours, for maintenance of traffic, for backfilling rock cuts, and for capping rock fills as specified in **303.09.C**.

**303.10 Shaping and Compaction**

**A. Final Shaping**

Immediately after spreading, shape the base material to the required degree of uniformity and smoothness. Except where using mechanical aggregate spreading equipment to place the base material, use a motor grader to shape each layer before compacting. If the mechanical spreading equipment fails to shape the base material properly, use a motor grader or other approved means to perform final shaping.

## **B. Compaction**

Compact the base material to the required density before any appreciable evaporation of surface moisture occurs. Continuously compact each layer until the minimum density requirement, as specified in **303.10.C.2**, is achieved. The Contractor may use any type of compacting equipment provided the required density is attained.

If, as provided for in **303.10.C.3**, the density requirement does not apply, gradually compact the base material, progressing from the edges of the base to the center, parallel with the center-line of the road. Continue compacting until the base layer has been compacted to its full width as directed by the Engineer. Where lifts of shoulder materials are placed to confine the base material, overlap the initial pass of the compacting equipment with the shoulder to a width of not less than 12 inches.

Construct the surface of each layer so that the aggregates become firmly keyed and a uniform texture is produced. Maintain the surface in this condition until it is covered by the following stage of construction or until final acceptance of the project. Correct irregularities by loosening the material at those places and adding or removing material as required.

Use approved distributors to apply water uniformly over the base materials during compaction in sufficient quantity to allow for proper compaction without causing softening of the underlying subgrade due to excessive water use.

## **C. Compaction Acceptance**

- 1. Lot Sizes and Testing.** For density testing purposes, the Department will divide each completed layer into lots of approximately 10,000 square yards, and will average the results of five density tests performed on each lot. Smaller lots may be considered as directed or approved by the Engineer.

## 2. Density Requirements

- a. **Type A Base.** The average density of each lot of Type A base, unless otherwise specified, shall be not less than 100% of maximum density as determined according to AASHTO T 99, Method D, with no individual test less than 97% of maximum density.
- b. **Type B Base.** The average density of each lot of Type B base, unless otherwise specified, shall be not less than 97% of maximum density as determined according to AASHTO T 99, Method D, with no individual test being less than 95% of maximum density.

If the specified density is not obtained for either type of base, rework or replace the material to comply with the density requirement.

3. **Exclusions.** Unless otherwise specified, the density requirements specified in **303.10.C.2** will not apply to:
  - a. Type A or Type B base construction on projects that do not include the construction of a surface upon the base, or to
  - b. Projects having a specified total base thickness of less than 4 inches.

When the specified density requirements do not apply, the Engineer will consider the desired degree of compaction to have been reached when the surface is tightly bound and shows no undue rutting or displacement under operation of the roller or other equipment. Obtain the Engineer's approval of the compaction of each layer before placing material for the next successive layer. Keep placing and compacting areas separate.

### 303.11 Maintenance

Maintain the completed base in a smooth and uniform condition until it is covered by the following stage of construction or the Project has been completed and accepted. Comply with the requirements of **104.05** regarding maintenance and protection.

### **303.12 Thickness Requirements**

The thickness of the completed base shall be in reasonably close conformity to the thickness shown on the Plans. The thickness will be measured at such frequency as established by the Department using test holes or other approved methods.

### **303.13 Surface Requirements**

The surface of the finished base shall be in reasonably close conformity to the lines, grades, and cross-sections shown on the Plans or established by the Engineer and shall have a satisfactorily smooth riding quality.

## **COMPENSATION**

### **303.14 Method of Measurement**

#### **A. Mineral Aggregate for Mineral Aggregate Base, Type A or Type B**

The Department will measure Mineral Aggregate for Mineral Aggregate Base, Type A or Type B, by the ton, in accordance with **109**.

#### **B. Water**

The Department will deduct the weight of total moisture, as determined by dry weights, of the base material at the time of weighing in excess of 3% of optimum moisture content.

The Department will not measure or pay for water when mixing is performed in a stationary plant,

When road mixing is performed, the Department will measure water added to the material at the direction of the Engineer by the M.G. (1,000 gallons) using calibrated tanks or distributors, or accurate water meters.

#### **C. Sodium Chloride**

The Department will measure sodium chloride by the ton in accordance with **109**.



**D. Calcium Chloride**

The Department will measure calcium chloride by the ton. The Department will weigh calcium chloride received in liquid form as specified in **109**, and will convert the weight of liquid calcium chloride to tons as follows:

**1. 32% Solution**

$$\text{Tons Calcium Chloride} = \frac{(\text{Total tons of 32\% solution}) \times 0.32}{0.94}$$

**2. 38 % Solution**

$$\text{Tons Calcium Chloride} = \frac{(\text{Total tons of 38\% solution}) \times 0.38}{0.94}$$

The Department will consider calcium chloride liquor used in a solution of 32% or more, but less than 38%, as a 32% solution. The Department will consider a solution of 38% or greater as a 38% solution.

**303.15 Basis of Payment**

The Department will pay for accepted quantities at the contract prices as follows:

<i>Item</i>	<i>Pay Unit</i>
Mineral Aggregate, Type ____ Base	Ton
Calcium Chloride	Ton
Sodium Chloride	Ton
Water	MG

The Department will pay for the work required to prepare the subgrade in accordance with **303.07** as provided for in the applicable Section or Subsection under which the work is performed.